

AMF

Harley-Davidson

PARTS CATALOG

1978

DE-40 Electric Golf Car

1976 to

ISSUED: FEBRUARY 1979

No. 99436-78

GENERAL INFORMATION

This Parts catalog has been prepared for your convenience when ordering parts for 1976 thru 1978 Model DE40 Electric Golf Car.

Number in parenthesis following description of part is the quantity needed for complete assembly shown in Illustration. If there is no number in parenthesis, only one is used.

Prices of all parts and accessories listed in this catalog are published separately in the latest RETAIL PRICE LIST.

The following instructions should be followed very carefully when ordering parts:

- Specify the correct part number on each item. Whenever in doubt about the model year, refer to the Vehicle Identification Number stamped on the frame.

Vehicle Identification Number (V. I. N.) is located on the frame under the left seat. The V. I. N. (vehicle identification number) for the DE40 model is as follows:

MODEL	First Two Digits (Model)	Next Five Digits (Sequential Number)	Second Last Digit (Manufacturer)	Last Digit (Model Season)
DE40	8D	10000 and up	H	6-1976 7-1977 8-1978

Example: 1978 DE40 (8D 12151 H8)

- An asterisk (*) in the used-on column indicates part is used for 1978 models (the latest model year covered by this catalog).
- Part Numbers are to be used when ordering by TELEGRAM or CABLE.
- When ordering parts use our standard parts order blank Part No. 99511-76, for all parts. The use of these blanks will enable us to fill and ship your order more promptly. These blanks are furnished free of charge upon request.
- Do not order golf cars or advertising matter on Parts Order Blanks. Write nothing on the order blank except the order itself, as any other correspondence will not be answered until the order is shipped and billed.
- Freight, Express and Parcel Post orders should be on separate order blanks.
- For your own records, number and date all orders, also keep a carbon copy for reference in case of misunderstanding.

COPYRIGHT 1979 BY HARLEY-DAVIDSON MOTOR CO., INC., ALL RIGHTS RESERVED.

Subsidiary of AMF Incorporated

Printed in U. S. A.

ALPHABETICAL INDEX

	Page		Page
Accelerator Pedal.....	3, 5	Motor.....	51, 53
Bag Holder.....	33	Numerical Index.....	61
Batteries.....	35	Rear Axle and Differential.....	55
Battery Charger.....	37, 39	Rear Suspension.....	25
Beverage Holder.....	23	Resistor.....	47, 49
Body.....	33	Seats.....	29, 31
Brake Cable.....	7, 9, 17	Seat Brake.....	27
Brake Caliper.....	17	Seat Lock.....	31
Brake Disc.....	15, 17	Shock Absorber.....	25
Brake Pedal.....	7, 9	Snap Switch.....	43, 45
Brake Shoes.....	15	Solenoids.....	47, 49
Bumpers.....	25	Speed Switch.....	43, 45
Buzzer.....	47, 49	Steering Wheel.....	19, 21
Cables.....	7, 9, 17, 27, 41	Suntop.....	57
Card Holder Assembly.....	19, 21	Switches.....	43, 45
Common Hardware.....	60	Tee & Golf Ball Holder.....	33
Differential.....	55	Tires.....	11
Floormat.....	23	Traction Motor - AMF.....	51
Front Housing.....	23	Traction Motor - GE.....	53
Front Suspension.....	13	Wheels.....	11
Ignition Switch.....	43, 45	Windshield.....	59
King Pin.....	13	Wiring.....	41

NOTICE

Harley-Davidson products are manufactured under one or more of the following U. S. patents: 2986162, 2987934, 2998809, 3116089, 3144631, 3144860, 3226994, 3229792, 3434887, 3559773, 3673359, 3680403, 3683716, 3709317. Des. 225626.

To the best knowledge of Harley-Davidson Motor Co., Inc. the material contained herein is accurate as of the date this publication was approved for printing. Harley-Davidson Motor Co., Inc. reserves the right to change specifications, equipment, or designs at any time without notice and without incurring obligation.

AMF HARLEY-DAVIDSON MOTOR CO., INC.

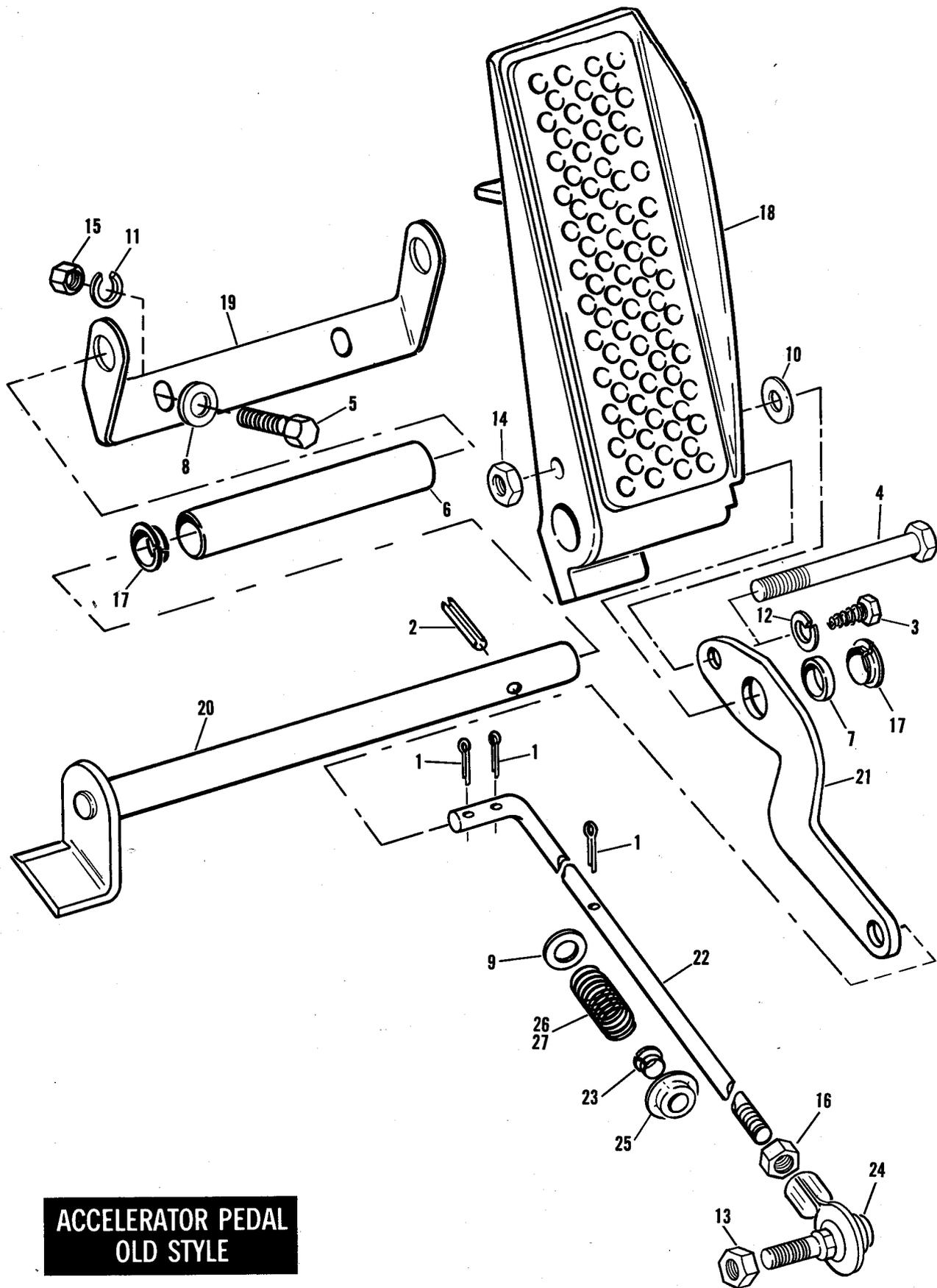

**ACCELERATOR PEDAL
OLD STYLE**

ACCELERATOR PEDAL – OLD STYLE

INDEX PART
NO. NO.

N A M E

U S E D O N

NOTE: For greater service reliability, we recommend updating your vehicle with the improvement parts listed on the next page.

1	515	COTTER PIN, 1/16 dia. x 1/2 (3)	76 & 77 – DE40
2	610	ROLL PIN, accelerator pedal.....	76 & 77 – DE40
3	2685W	SCREW, No. 10-24 x 5/8 self tapping hex. hd.	76 – DE40
4	3650	BOLT, 1/4-20 x 3 hex. hd.	77 – DE40
5	3987	BOLT, 5/16-18 x 3/4 hex. hd. (2)	76 & 77 – DE40
6	5745	SPACER, accelerator shaft – long	76 & 77 – DE40
7	5746	SPACER, accelerator shaft – short.....	76 & 77 – DE40
8	6333	WASHER, 5/16 x 7/8 x 5/64 (2).....	76 & 77 – DE40
9	6702	WASHER, 5/16 x 11/16 x 1/16.....	76 & 77 – DE40
10	6703	WASHER, 1/4 x 5/8 x 1/16.....	77 – DE40
11	7041	LOCKWASHER, 5/16 (2).....	76 & 77 – DE40
12	7069	LOCKWASHER, No. 10.....	76 – DE40
13	7727	LOCKNUT, 5/16-24 x 1/4 x 1/2 hex.....	76 & 77 – DE40
14	7742	LOCKNUT, 1/4-20 x 7/32 x 7/16 hex.....	77 – DE40
15	7748W	NUT, 5/16-18 x 1/4 x 1/2 hex. (2).....	76 & 77 – DE40
16	7753	NUT, 5/16-24 x 1/4 x 1/2 hex.	76 & 77 – DE40
17	40522-63	BUSHING, shaft (2)	76 & 77 – DE40
18	40537-75	ACCELERATOR PEDAL.....	76 & 77 – DE40
19	40538-75	BRACKET, accelerator pedal shaft.....	76 & 77 – DE40
20	40539-75	SHAFT, accelerator pedal.....	76 & 77 – DE40
21	40543-75	LEVER, accelerator pedal	76 & 77 – DE40
22	40546-75	ACCELERATOR ROD, only	76 & 77 – DE40
23	40547-75	BEARING SLEEVE, spring retainer	76 & 77 – DE40
24	42468-75	END, accelerator rod (ball joint).....	76 & 77 – DE40
25	47743-63	RETAINER, accelerator rod.....	76 & 77 – DE40
26	71513-66A	SPRING, accelerator rod.....	76 – DE40
27	71770-77	SPRING, accelerator rod.....	77 – DE40

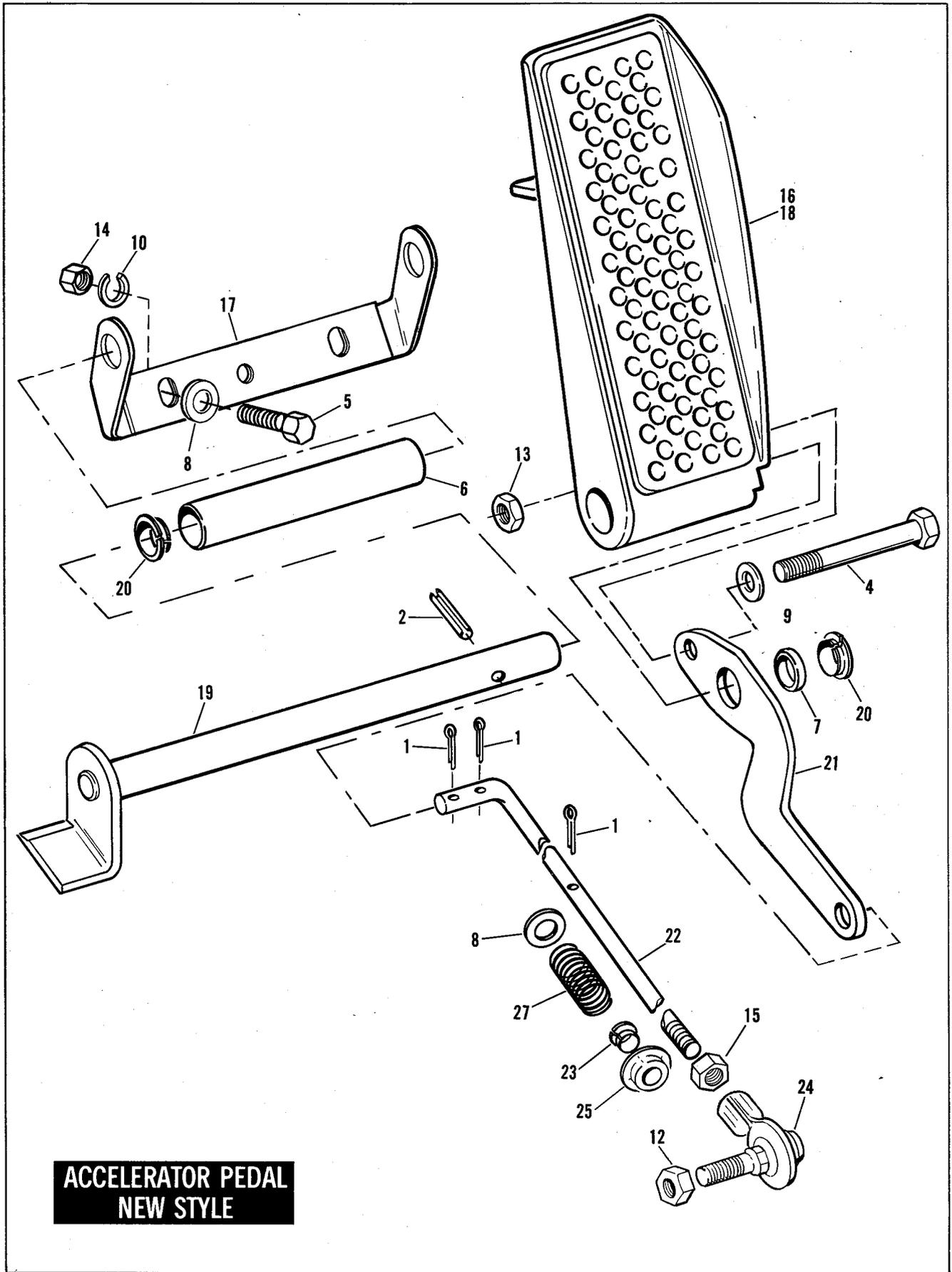

**ACCELERATOR PEDAL
NEW STYLE**

ACCELERATOR PEDAL – NEW STYLE

INDEX NO.	PART NO.	N A M E	U S E D O N
1	515	COTTER PIN, 1/16 dia. x 1/2 (3)	76 to * – DE40
2	610	ROLL PIN, accelerator pedal	76 to * – DE40
4	3650	BOLT, 1/4-20 x 3 hex. hd.	77 to * – DE40
5	3991	BOLT, 5/16-18 x 7/8 hex. hd. (3)	76 to * – DE40
6	5745	SPACER, accelerator shaft – long	76 to * – DE40
7	5746	SPACER, accelerator shaft – short	76 to * – DE40
8	6702	WASHER, 5/16 x 11/16 x 1/16 (4)	76 to * – DE40
9	6703	WASHER, 1/4 x 5/8 x 1/16	77 to * – DE40
10	7041	LOCKWASHER, 5/16 (3)	76 to * – DE40
12	7727	LOCKNUT, 5/16-24 x 1/4 x 1/2 hex.	76 to * – DE40
13	7742	LOCKNUT, 1/4-20 x 7/32 x 7/16 hex.	77 to * – DE40
14	7748W	NUT, 5/16-18 x 1/4 x 1/2 hex. (3)	76 to * – DE40
15	7753	NUT, 5/16-24 x 1/4 x 1/2 hex.	76 to * – DE40
16	40450-78	ACCELERATOR PEDAL	76 to * – DE40
17	40451-78	BRACKET, accelerator pedal shaft	76 to * – DE40
18	40453-78	ACCELERATOR PEDAL ASSEMBLY	76 to * – DE40
19	40455-78	SHAFT, accelerator pedal	76 to * – DE40
20	40522-63	BUSHING, shaft (2)	76 to * – DE40
21	40543-75	LEVER, accelerator pedal	76 to * – DE40
22	40546-75	ACCELERATOR ROD, only	76 to * – DE40
23	40547-75	BEARING SLEEVE, spring retainer	76 to * – DE40
24	42468-75	END, accelerator rod (ball joint)	76 to * – DE40
25	47743-63	RETAINER, accelerator rod	76 to * – DE40
27	71770-77	SPRING, accelerator rod	77 to * – DE40

NOTE: For increased reliability, 1976 and 1977 models should be updated to 1978 vehicle specifications by installing the following Kit:

47738-78	BRAKE AND ACCELERATOR PEDAL KIT	76 to * – DE40
	Consists of:	
	515	COTTER PIN, 1/16 dia. x 1/2
	559	COTTER PIN, 1/8 dia. x 1-1/4 (2)
	2551W	BOLT, 1/4-20 x 1 hex. hd. (2)
	2685W	SCREW, No. 10-24 x 5/8 self tapping hex. hd. (2)
	3213	SET SCREW, 1/4-28 x 3/4 square hd.
	3767B	BOLT, 1/4-20 x 5/8 hex. hd.
	3854	BOLT, 7/16-14 x 1 hex. hd. (3)
	3987	BOLT, 5/16-18 x 3/4 hex. hd. (7)
	3991	BOLT, 5/16-18 x 7/8 hex. hd. (9)
	6701	WASHER, 3/8 x 13/16 x 1/16 (2)
	6702	WASHER, 5/16 x 11/16 x 1/16 (18)
	6703	WASHER, 1/4 x 5/8 x 1/16 (2)
	7039	LOCKWASHER, 7/16 (3)
	7041	LOCKWASHER, 5/16 (16)
	7686	LOCKNUT, 1/4-20 x 5/16 x 7/16 hex. (2)
	7748W	NUT, 5/16-18 x 1/4 x 1/2 hex. (16)
	7775	LOCKNUT, 3/8-24 x 7/16 x 9/16 hex. (2)
	10006	CABLE STRAP
	40453-78	ACCELERATOR PEDAL ASSEMBLY
	41528-78	BRACKET, brake cable stop
	41531-78	SPRING DAMPER, brake cable
	41537-78	SPRING, extension – damper (2)
	41538-78	CLEVIS PIN, spring damper (2)
	42600-78	BRAKE CALIPER AND CABLE
	42602-78	BUMPER PAD, brake pedal
	42629-78	CABLE GUIDE
	42633-78	BRACKET, brake support
	42642-78	BRAKE PEDAL ASSEMBLY
	43803-78	REINFORCEMENT, upper
	43808-78	REINFORCEMENT, lower
	47781-78	BRAKE DISC AND HUB
	83190-75	STRAIGHT KEY, traction motor

NOTE: Asterisk (*) indicates part is used for latest model year shown on cover

BRAKE PEDAL OLD STYLE

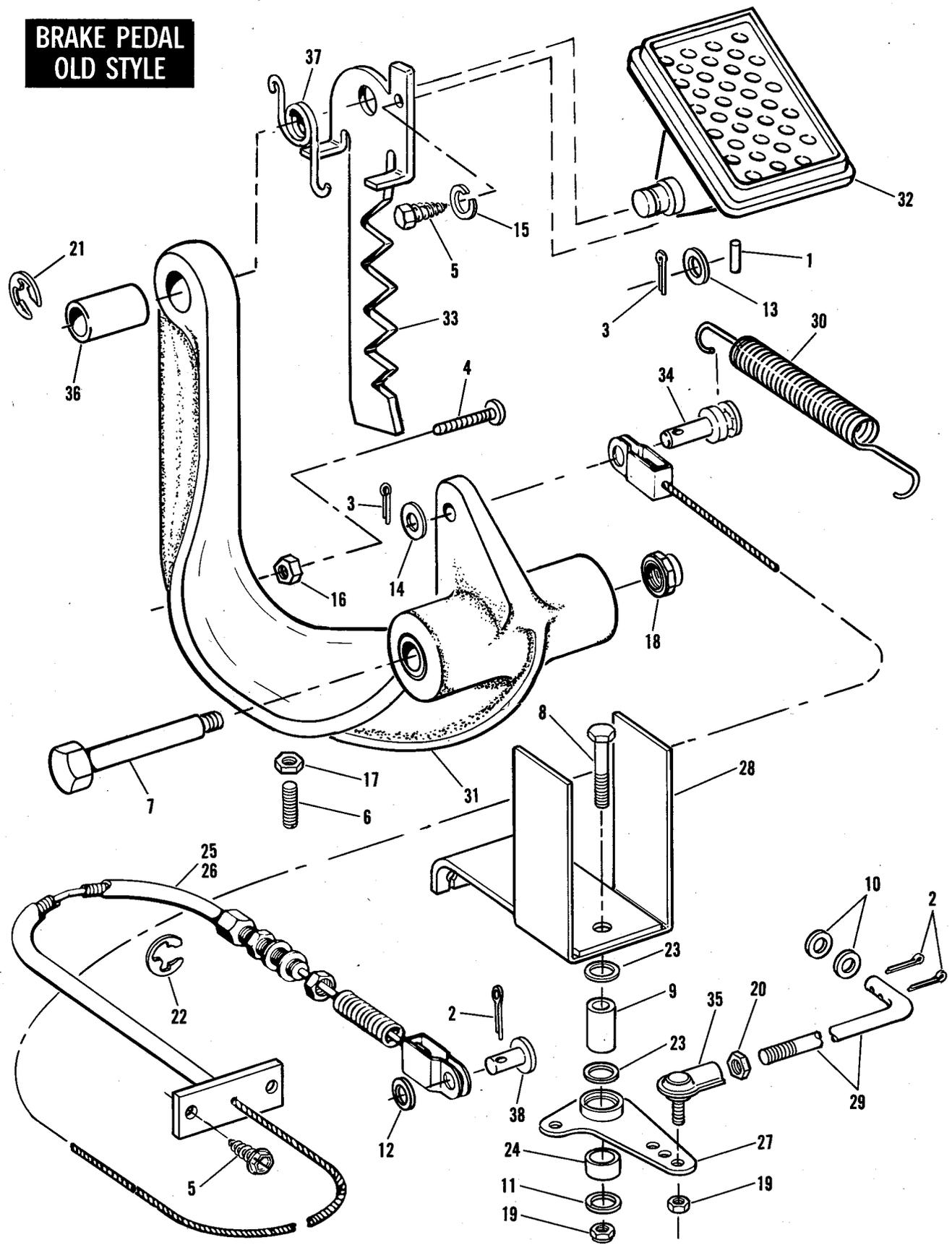

BRAKE PEDAL - OLD STYLE

INDEX PART

NO. NO.

N A M E

USED ON

NOTE: For greater service reliability, we recommend updating your vehicle with the improvement parts listed on the next page.

1	384	ROLL PIN	77 - DE40
2	515	COTTER PIN, 1/16 dia. x 3/4 (3 - 77).....	76 & 77 - DE40
3	534	COTTER PIN, 3/32 dia. x 1 (2 - 77).....	76 & 77 - DE40
4	2560	SCREW, No. 10-24 x 1-1/4 self tapping Pozidriv pan hd.....	76 & 77 - DE40
5	2685W	SCREW, No. 10-24 x 5/8 self tapping hex. hd. (3 - 77).....	76 & 77 - DE40
6	3245	SET SCREW, 1/4-20 x 1-1/4 slot end.....	Early 77 - DE40
7	4455	SHOULDER BOLT, brake lever.....	76 & 77 - DE40
8	4730	BOLT, 5/16-24 x 1-3/4 hex. hd.....	77 - DE40
9	5982W	SPACER, brake pivot lever.....	77 - DE40
10	6310B	WASHER, 5/16 x 9/16 x 1/32 (2).....	77 - DE40
11	6336B	WASHER, 5/16 x 15/16 x 5/32.....	77 - DE40
12	6375B	WASHER, 3/8 x 9/16 x 1/32.....	76 & 77 - DE40
13	6701	WASHER, 3/8 x 13/16 x 1/16.....	77 - DE40
14	6702	WASHER, 5/16 x 11/16 x 1/16.....	76 & 77 - DE40
15	7069	LOCKWASHER, No. 10.....	76 & 77 - DE40
16	7620W	NUT, No. 10-24 x 1/8 x 3/8 hex.	76 - DE40
17	7688	NUT, 1/4-20 x 7/32 x 7/16 hex.	Early 77 - DE40
18	7727	LOCKNUT, 5/16-24 x 1/4 x 1/2 hex.....	76 & 77 - DE40
19	7729	LOCKNUT, 5/16-24 x 1/4 x 1/2 hex. (2).....	77 - DE40
20	7753	NUT, 5/16-24 x 1/4 x 1/2 hex.....	77 - DE40
21	11000	RETAINING RING, pedal	76 - DE40
22	11036	RETAINING RING, brake control cable	76 & 77 - DE40
23	11115	O-RING, brake pivot lever.....	77 - DE40
24	25594-75	BUSHING, brake pivot lever.....	77 - DE40
25	40940-75	BRAKE CONTROL CABLE ASSEMBLY.....	76 - DE40
26	40940-77	BRAKE CONTROL CABLE ASSEMBLY.....	77 - DE40
27	41510-77	LEVER, brake pivot.....	77 - DE40
28	41513-77	BRACKET, brake pivot lever.....	77 - DE40
29	41516-77	BRAKE ROD	77 - DE40
30	41834-67	SPRING, brake lever return.....	76 & 77 - DE40
31	42462-75A	BRAKE LEVER.....	76 & 77 - DE40
32	42464-75A	BRAKE PEDAL.....	76 & 77 - DE40
33	42466-75B	RATCHET, brake lever.....	76 & 77 - DE40
34	42467-75	CLEVIS PIN, brake cable (pedal end).....	76 & 77 - DE40
35	42468-75	END, brake rod.....	77 - DE40
36	42482-63	BUSHING, brake lever.....	76 & 77 - DE40
37	42494-63B	SPRING, brake lever ratchet.....	76 & 77 - DE40
38	73092-61B	CLEVIS PIN, brake cable (brake end).....	76 & 77 - DE40

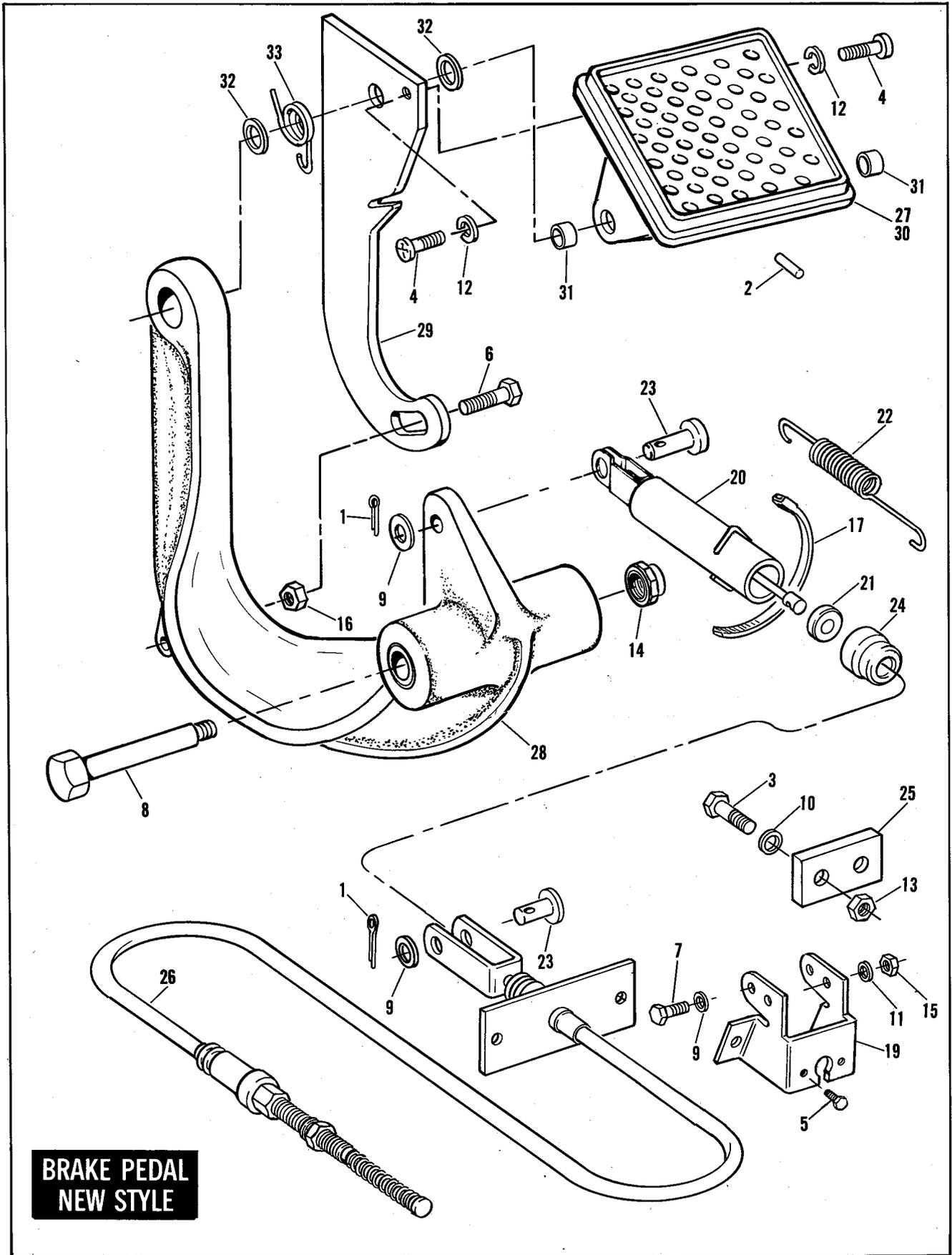

BRAKE PEDAL – NEW STYLE

INDEX NO.	PART NO.	NAME	USED ON
1	559	COTTER PIN, 1/8 dia. x 1-1/4 (2).....	76 to * – DE40
2	610	ROLL PIN, brake pedal.....	76 to * – DE40
3	2551W	BOLT, 1/4-20 x 1 hex. hd. (2).....	76 to * – DE40
4	2659	SCREW, No. 10-24 x 7/8 Pozidriv pan hd. (2).....	76 to * – DE40
5	2685W	SCREW, No. 10-24 x 5/8 self tapping hex. hd. (2).....	76 to * – DE40
6	3459	BOLT, 5/16-18 x 1-1/2 hex. washer hd.	76 to * – DE40
7	3987	BOLT, 5/16-18 x 3/4 hex. hd. (4).....	76 to * – DE40
8	4455	SHOULDER BOLT, brake lever.....	76 to * – DE40
9	6702	WASHER, 5/16 x 11/16 x 1/16 (6).....	76 to * – DE40
10	6703	WASHER, 1/4 x 5/8 x 1/16 (2).....	76 to * – DE40
11	7041	LOCKWASHER, 5/16 (4).....	76 to * – DE40
12	7069	LOCKWASHER, No. 10 (2).....	76 to * – DE40
13	7686	LOCKNUT, 1/4-20 x 5/16 x 7/16 hex. (2).....	76 to * – DE40
14	7727	LOCKNUT, 5/16-24 x 1/4 x 1/2 hex.....	76 to * – DE40
15	7748W	NUT, 5/16-18 x 1/4 x 1/2 hex. (4).....	76 to * – DE40
16	7763W	JAM NUT, 5/16-18 x 3/16 x 1/2 hex.....	76 to * – DE40
17	10006	STRAP, rubber boot.....	76 to * – DE40
19	41528-78	BRACKET, brake cable stop.....	76 & 77 – DE40
20	41531-78	SPRING DAMPER, brake cable.....	76 to * – DE40
21	41534-78	SPACER, spring damper.....	76 to * – DE40
22	41537-78	SPRING, extension – damper (2).....	76 to * – DE40
23	41538-78	CLEVIS PIN, spring damper (2).....	76 to * – DE40
24	41542-78	RUBBER BOOT, spring damper.....	76 to * – DE40
25	42602-78	BUMPER PAD, brake pedal.....	76 to * – DE40
26	42617-78	BRAKE CABLE AND PAD SET.....	76 to * – DE40
27	42634-78	BRAKE PEDAL.....	76 to * – DE40
28	42636-78	BRAKE LEVER.....	76 to * – DE40
29	42639-78	RATCHET, brake lever.....	76 to * – DE40
30	42642-78	BRAKE PEDAL ASSEMBLY.....	76 to * – DE40
31	42643-78	BUSHING, brake pedal (2).....	76 to * – DE40
32	42644-78	WASHER, brake pedal (2).....	76 to * – DE40
33	42645-78	SPRING, brake ratchet.....	76 to * – DE40

NOTE: For increased reliability, 1976 and 1977 models should be updated to 1978 vehicle specifications by installing the following Kit:

47738-78	BRAKE AND ACCELERATOR PEDAL KIT.....	76 to * – DE40
	Consists of:	
515	COTTER PIN, 1/16 dia. x 1/2	
559	COTTER PIN, 1/8 dia. x 1-1/4 (2)	
2551W	BOLT, 1/4-20 x 1 hex. hd. (2)	
2685W	SCREW, No. 10-24 x 5/8 self tapping hex. hd. (2)	
3213	SET SCREW, 1/4-28 x 3/4 square hd.	
3767B	BOLT, 1/4-20 x 5/8 hex. hd.	
3854	BOLT, 7/16-14 x 1 hex. hd. (3)	
3987	BOLT, 5/16-18 x 3/4 hex. hd. (7)	
3991	BOLT, 5/16-18 x 7/8 hex. hd. (9)	
6701	WASHER, 3/8 x 13/16 x 1/16 (2)	
6702	WASHER, 5/16 x 11/16 x 1/16 (8)	
6703	WASHER, 1/4 x 5/8 x 1/16 (2)	
7039	LOCKWASHER, 7/16 (3)	
7041	LOCKWASHER, 5/16 (16)	
7686	LOCKNUT, 1/4-20 x 5/16 x 7/16 hex. (2)	
7748W	NUT, 5/16-18 x 1/4 x 1/2 hex. (16)	
7775	LOCKNUT, 3/8-24 x 7/16 x 9/16 hex. (2)	
10006	CABLE STRAP	
40453-78	ACCELERATOR PEDAL ASSEMBLY	
41528-78	BRACKET, brake cable stop	
41531-78	SPRING DAMPER, brake cable	
41537-78	SPRING, extension – damper (2)	
41538-78	CLEVIS PIN, spring damper (2)	
42600-78	BRAKE CALIPER AND CABLE	
42602-78	BUMPER PAD, brake pedal	
42629-78	CABLE GUIDE	
42633-78	BRACKET, brake support	
42642-78	BRAKE PEDAL ASSEMBLY	
43803-78	REINFORCEMENT, upper	
43808-78	REINFORCEMENT, lower	
47781-78	BRAKE DISC AND HUB	
83190-75	STRAIGHT KEY, traction motor	

NOTE: Asterisk (*) indicates part is used for latest model year shown on cover.

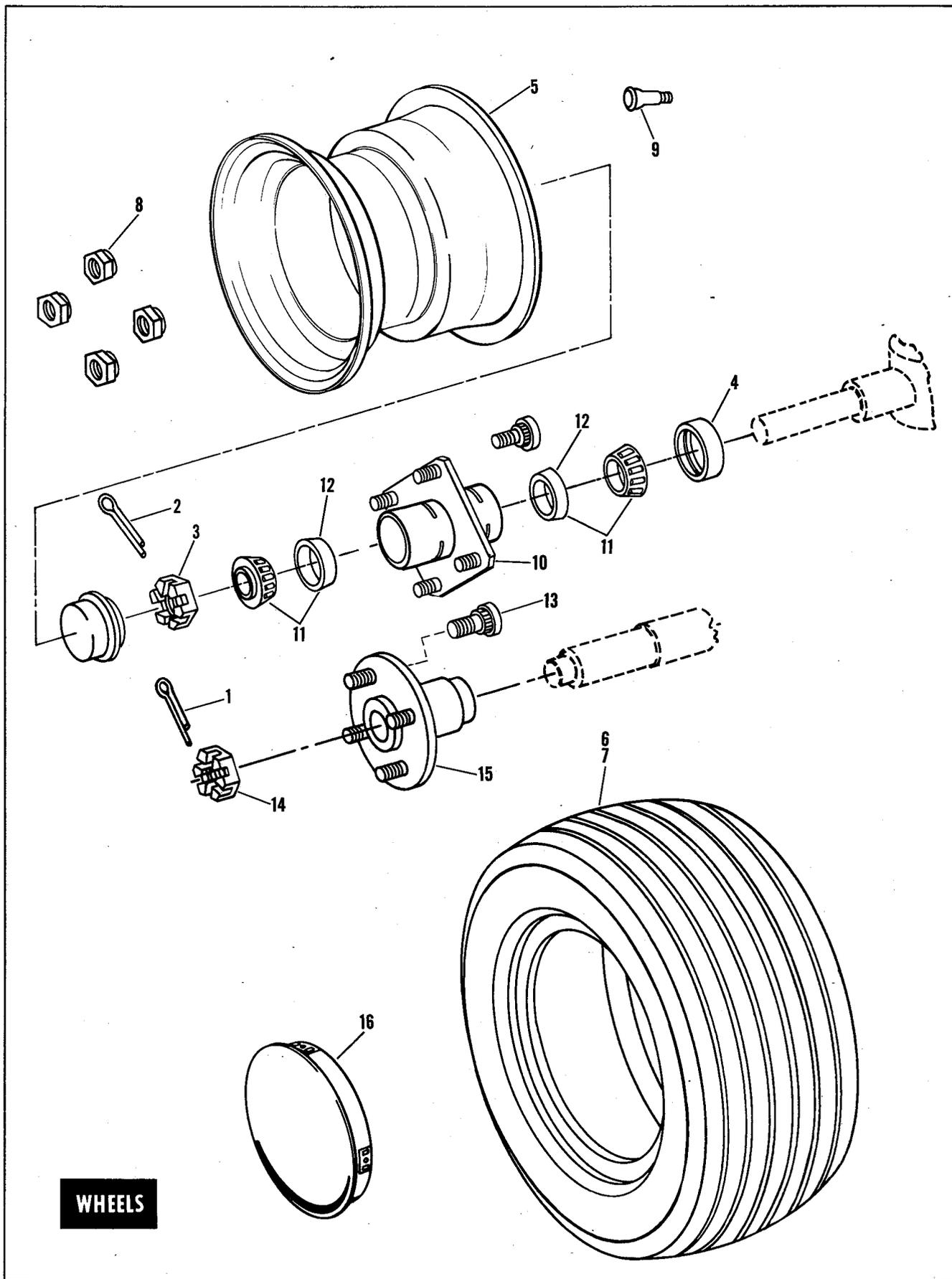

WHEELS

WHEELS

INDEX NO.	PART NO.	N A M E	USED ON
1	559	COTTER PIN, 1/8 dia. x 1-1/4 (2).....	76 to * - DE40
2	576	COTTER PIN, 1/8 dia. x 1-3/4 (2).....	76 to * - DE40
3	7874	CASTLE NUT, 1-12 x 7/8 x 1-1/2 hex. (2).....	76 to * - DE40
4	12028	OIL SEAL, front wheel hub	76 to * - DE40
5	43017-66B	WHEEL, 8 in. (4).....	76 to * - DE40
6	43103-72	TIRE, rib tread (8.50 x 8 - 4 ply).....	76 to * - DE40
7	43104-72	TIRE, traction tread (8.50 x 8 - 4 ply)	76 to * - DE40
8	43152-66	NUT, wheel (16).....	76 to * - DE40
9	43156-63	VALVE WITH CORE.....	76 to * - DE40
10	43480-75	HUB, front wheel, with bearings and seal (2).....	76 to * - DE40
11	48300-60	BEARING CUP AND CONE, front wheel (2)	76 to * - DE40
12	48315-60	BEARING CUP, only - front wheel (2).....	76 to * - DE40
13	83085-73	STUD, rear hub (8).....	76 to * - DE40
14	83131-63	NUT, rear axle shaft (2)	76 to * - DE40
15	83142-75	HUB, rear wheel (2).....	76 to * - DE40
16	83961-63A	WHEEL COVER (4).....	76 to * - DE40

NOTE: Asterisk (*) indicates part is used for latest model year shown on cover.

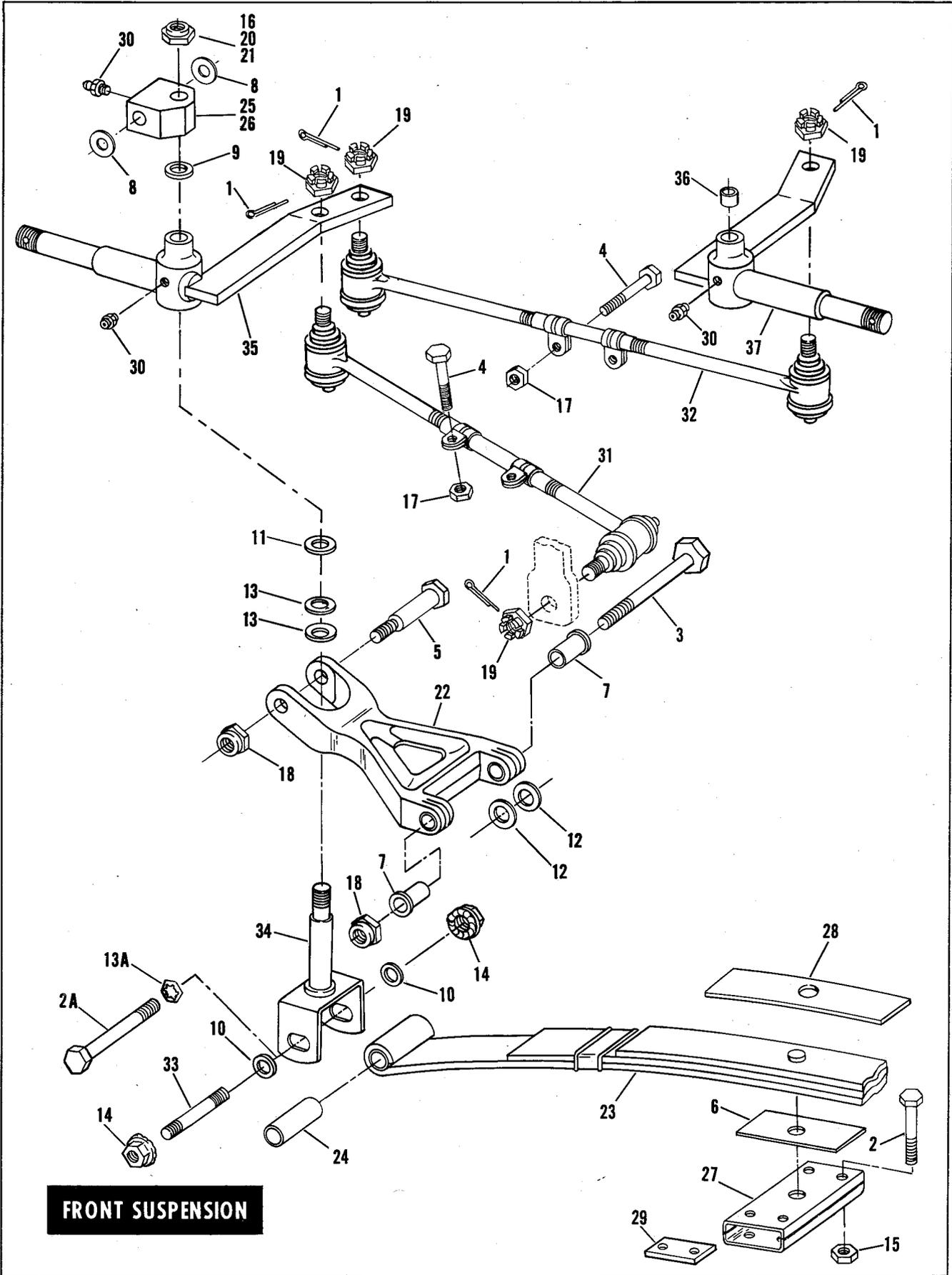

FRONT SUSPENSION

INDEX NO.	PART NO.	NAME	USED ON
1	520W	COTTER PIN, 1/8 dia. x 1 (8)	76 to * - DE40
2	3449	BOLT, 5/16-24 x 2-1/4 hex. hd. (4)	76 to * - DE40
2A	3455	BOLT, 3/8-24 x 3-3/4 hex. hd. (2)	76 & 77 - DE40
3	3456	PIVOT BOLT, 3/8-24 x 7 hex. hd. (2)	76 to * - DE40
4	4014W	BOLT, 5/16-24 x 1-1/4 hex. hd. (4)	76 to * - DE40
5	4250	SHOULDER BOLT, pivot block (2)	76 to * - DE40
6	5748	SPACER, leaf spring mounting - lower	76 to * - DE40
7	5749	SPACER, a-frame pivot (4)	76 to * - DE40
8	6346	WASHER, 1/2 x 1-3/8 x 1/32 Delrin (4)	76 to * - DE40
9	6347	THRUST WASHER, 5/8 x 1-1/4 x 1/8 (bronze) (2)	76 to * - DE40
10	6417W	WASHER, 3/8 x 1-1/8 x 1/8 (4)	76 to * - DE40
11	6653	WASHER, 5/8 x 1-5/16 x 3/32 (2)	Late 76 to * - DE40
12	6698	THRUST WASHER, 5/8 x 1-7/16 x 1/16 (bronze) (4)	76 to * - DE40
13	6926	BELLEVILLE SPRING WASHER, 5/8 x 1-1/4 x 3/64 (4)	76 to * - DE40
13A	7420	SPECIAL LOCKWASHER, leaf spring end	76 & 77 - DE40
14	7512	LOCKNUT, 3/8-16 x 9/16 hex. washer (4)	76 to * - DE40
15	7725	LOCKNUT, 5/16-24 x 11/32 x 1/2 hex. (4)	76 to * - DE40
16	7741	LOCKNUT, 1/2-20 x 1/2 x 3/4 hex. (2)	Late 77 to * - DE40 (Above 8D 10057 H7)
17	7753	NUT, 5/16-24 x 1/4 x 1/2 hex. (4)	76 to * - DE40
18	7775	LOCKNUT, 3/8-24 x 7/16 x 9/16 hex. (6) (4 - Late 77 & later)	76 to * - DE40
19	7867W	CASTLE NUT, 7/16-20 (4)	76 to * - DE40
20	7990	LOCKNUT, 5/8-18 x 3/8 x 15/16 hex. (2)	Late 76 to Early 77 - DE40 (Below 8D 10058 H7)
21	7995	LOCKNUT, 5/8-18 x 3/8 x 15/16 hex. (2)	Early 76 - DE40
22	43930-75	A-FRAME (2)	76 to * - DE40
23	43933-75	LEAF SPRING	76 to * - DE40
24	43935-75A	SPACER, leaf spring end (2)	76 to * - DE40
25	43936-75	PIVOT BLOCK (2)	76 to Early 77 - DE40 (Below 8D 10058 H7)
26	43936-77	PIVOT BLOCK (2)	Late 77 to * - DE40 (Above 8D 10057 H7)
27	47598-75	RETAINER PLATE, leaf spring	76 to * - DE40
28	47605-75	RUBBER INSERT, leaf spring	76 to * - DE40
29	47618-77	REINFORCEMENT PLATE, leaf spring retainer (2)	77 to * - DE40
30	50972-75	GREASE FITTING (4)	76 to * - DE40
31	57120-75	TIE ROD, short	76 to * - DE40
32	57130-75	TIE ROD, long	76 to * - DE40
33	57196-78	STUD, 3/8-16 thread - both ends (2)	76 to * - DE40
34	57199-78	KING PIN (2)	Late 77 to * - DE40 (Above 8D 10057 H7)
35	57210-75	STEERING ARM, right	76 to * - DE40
36	57215-75	BUSHING, steering arm (2)	76 to * - DE40
37	57220-75	STEERING ARM, left	76 to * - DE40

NOTE: For increased reliability, 1976 and 1977 models should be updated to 1978 vehicle specifications by installing the following Kit:

57225-78	KING PIN KIT (2)	76 to * - DE40
	Consists of:	
4250	SHOULDER BOLT, pivot block	
6346	WASHER, 1/2 x 1-3/8 x 1/32 Delrin (2)	
6347	THRUST WASHER, 5/8 x 1-7/16 x 1/16 (bronze)	
6417W	WASHER, 3/8 x 1-1/8 x 1/8 (2)	
6653	WASHER, 5/8 x 1-5/16 x 3/32	
6926	BELLEVILLE SPRING WASHER, 5/8 x 1-1/4 x 3/64 (2)	
7512	LOCKNUT, 3/8-16 x 9/16 hex. (2)	
7741	LOCKNUT, 1/2-20 x 1/2 x 3/4 hex.	
7775	LOCKNUT, 3/8-24 x 7/16 x 9/16 hex.	
43935-75A	SPACER, leaf spring end	
43936-77	PIVOT BLOCK	
57196-78	STUD, 3/8-16 thread - both ends	
57199-78	KING PIN	

NOTE: Asterisk (*) indicates part is used for latest model year shown on cover.

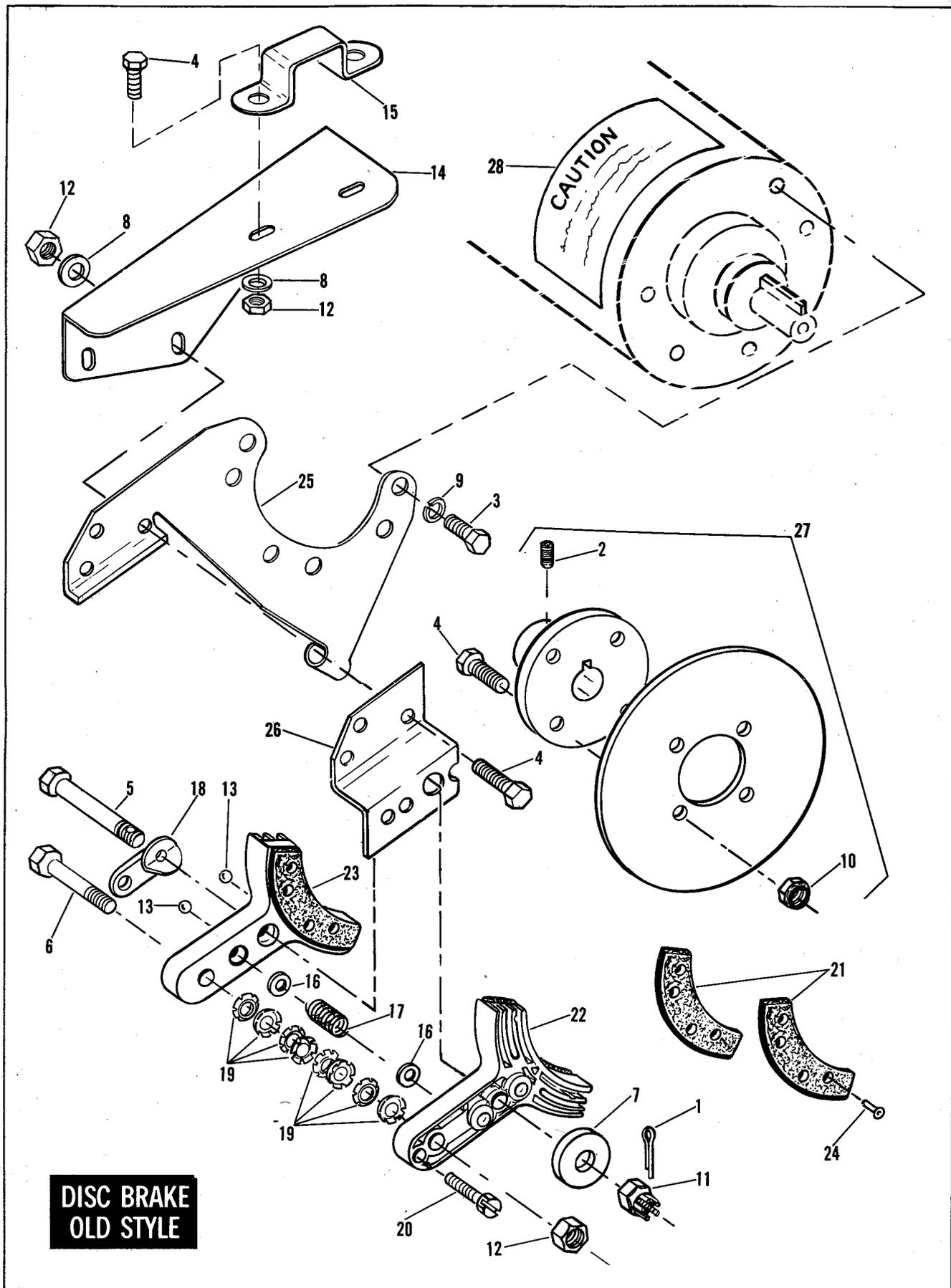

DISC BRAKE – OLD STYLE

INDEX NO.	PART NO.	NAME	USED ON
-----------	----------	------	---------

NOTE: For greater service reliability, we recommend updating your vehicle with the improvement parts listed on the next page.

1	515	COTTER PIN, 1/16 dia. x 3/4	76 & 77 – DE40
2	3240	SET SCREW, 1/4-20 x 1/2 socket hd.	76 & 77 – DE40
3	3767B	BOLT, 1/4-20 x 5/8 hex. hd. (3)	76 & 77 – DE40
4	3960W	BOLT, 5/16-24 x 1 hex. hd. (8)	76 & 77 – DE40
5	4064W	BOLT, 5/16-24 x 3-3/4 hex. hd. (drilled).....	76 & 77 – DE40
6	4725	BOLT, 5/16-24 x 2-3/4 hex. hd.	76 & 77 – DE40
7	5998	SPACER	76 & 77 – DE40
8	6702	WASHER, 5/16 x 11/16 x 1/16 (4).....	76 & 77 – DE40
9	7036	LOCKWASHER, 1/4 (3).....	76 & 77 – DE40
10	7727	LOCKNUT, 5/16-24 x 1/4 x 1/2 hex. (4).....	76 & 77 – DE40
11	7728	CASTLE NUT, 5/16-24 x 5/16 x 1/2 hex.	76 & 77 – DE40
12	7729	LOCKNUT, 5/16-24 x 1/4 x 1/2 hex. (5).....	76 & 77 – DE40
13	8858	BALL, cam lever	76 & 77 – DE40
14	16280-76	BRACE, motor.....	76 – DE40
	16280-77	BRACE, motor (black).....	77 – DE40
15	16281-76	BRACKET, motor brace.....	76 & 77 – DE40
16	33256-71	WASHER, spring seat (2).....	76 & 77 – DE40
17	38078-47	SPRING, brake shoe.....	76 & 77 – DE40
18	41421-72	CAM LEVER	76 – DE40
	41421-77	CAM LEVER	77 – DE40
19	41424-63	SPRING WASHER (8)	76 & 77 – DE40
	41781-75	BRAKE SHOE ASSEMBLY, complete	76 – DE40
	41781-77	BRAKE SHOE ASSEMBLY, complete	77 – DE40
20	41782-75	BOLT, brake shoe stop.....	76 & 77 – DE40
21	41810-64A	SET OF BRAKE LININGS AND RIVETS.	76 & 77 – DE40
22	41811-64A	BRAKE SHOE, front.....	76 & 77 – DE40
23	41811-71	BRAKE SHOE, rear	76 & 77 – DE40
24	41841-63	RIVET, brake lining (8).....	76 & 77 – DE40
25	47745-72	BRACKET, brake mounting.....	76 & 77 – DE40
26	47748-72	BRACKET, brake shoe	76 & 77 – DE40
27	47781-78	BRAKE DISC AND HUB.....	76 & 77 – DE40
28	52083-72	CAUTION LABEL, brake adjustment	76 & 77 – DE40

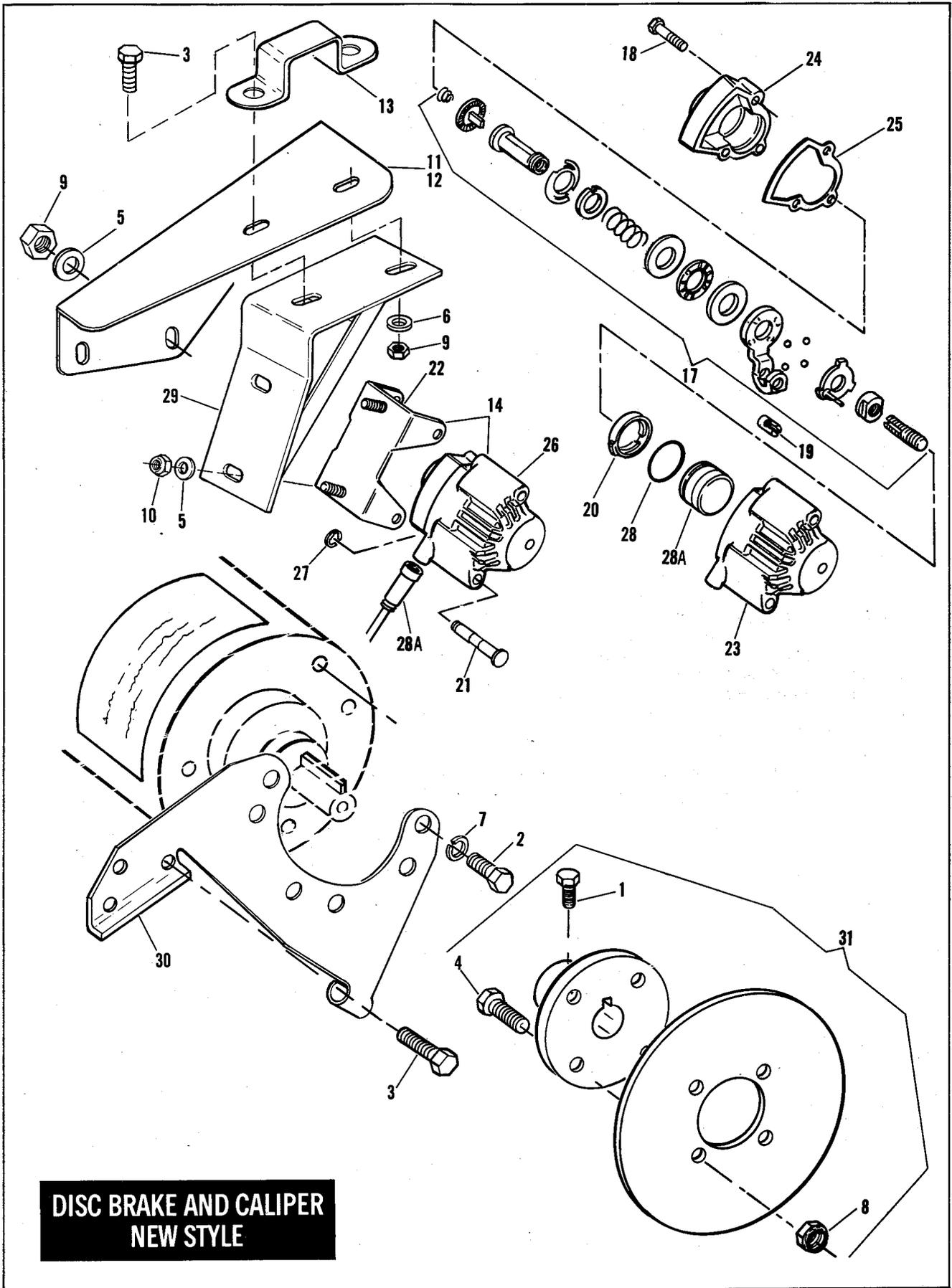

**DISC BRAKE AND CALIPER
NEW STYLE**

DISC BRAKE AND CALIPER – NEW STYLE

INDEX PART		NAME	USED ON
NO.	NO.		
1	3213	SET SCREW, 1/4-28 x 3/4 square hd. w/lock patch	76 to * – DE40
2	3767B	BOLT, 1/4-20 x 5/8 hex. hd. (3)	76 to * – DE40
3	3960W	BOLT, 5/16-24 x 1 hex. hd. (4)	76 to * – DE40
4	3996	BOLT, 5/16-24 x 7/8 hex. hd. (4)	76 to * – DE40
5	6701	WASHER, 3/8 x 13/16 x 1/16 (4)	76 to * – DE40
6	6702	WASHER, 5/16 x 11/16 x 1/16 (4)	76 to * – DE40
7	7036	LOCKWASHER, 1/4 (3)	76 to * – DE40
8	7727	LOCKNUT, 5/16-24 x 1/4 x 1/2 hex. (4)	76 to * – DE40
9	7729	LOCKNUT, 5/16-24 x 1/4 x 1/2 hex. (4)	76 to * – DE40
10	7775	LOCKNUT, 3/8-24 x 7/16 x 9/16 hex. (2)	76 to * – DE40
11	16280-76	BRACE, motor.	76 – DE40
12	16280-77	BRACE, motor.	77 to * – DE40
13	16281-76	BRACKET, motor brace.	76 to * – DE40
14	42600-78	NISSAN BRAKE CALIPER & CABLE	76 to * – DE40
17	42604-78	RATCHET GEAR AND ARM ASSEMBLY	76 to * – DE40
18	42605-78	BOLT, cover.	76 to * – DE40
19	42606-78	PIN, brake cable lock	76 to * – DE40
20	42607-78	GUIDE, ratchet gear.	76 to * – DE40
21	42608-78	PIN SET, consists of pin and E-ring.	76 to * – DE40
22	42609-78	BRACKET, caliper mounting	76 to * – DE40
23	42610-78	BODY, caliper.	76 to * – DE40
24	42611-78	COVER, caliper body.	76 to * – DE40
25	42612-78	GASKET, cover.	76 to * – DE40
26	42613-78	CALIPER ASSEMBLY	76 to * – DE40
27	42615-78	E-RING, bracket pin.	76 to * – DE40
28	42616-78	O-RING, ratchet guide	76 to * – DE40
28A	42617-78	BRAKE CABLE AND PAD SET	76 to * – DE40
		Includes besides cable & pads:	
	559	COTTER PIN, 1/8 dia. x 1-1/4	
	2685W	SCREW, No. 10-24 x 5/8 self tapping hex. hd. (2)	
29	42633-78	BRACKET, brake support	76 to * – DE40
30	47745-72	BRACKET, brake mounting.	76 to * – DE40
31	47781-78	BRAKE DISC AND HUB.	76 to * – DE40

NOTE: For increased reliability, 1976 and 1977 models should be updated to 1978 vehicle specifications by installing the following Kit:

47738-78	BRAKE AND ACCELERATOR PEDAL KIT.	76 to * – DE40
	Consists of:	
515	COTTER PIN, 1/16 dia. x 1/2	
559	COTTER PIN, 1/8 dia. x 1-1/4 (2)	
2551W	BOLT, 1/4-20 x 1 hex. hd. (2)	
2685W	SCREW, No. 10-24 x 5/8 self tapping hex. hd. (2)	
3213	SET SCREW, 1/4-28 x 3/4 square hd.	
3767B	BOLT, 1/4-20 x 5/8 hex. hd.	
3854	BOLT, 7/16-14 x 1 hex. hd. (3)	
3987	BOLT, 5/16-18 x 3/4 hex. hd. (7)	
3991	BOLT, 5/16-18 x 7/8 hex. hd. (9)	
6701	WASHER, 3/8 x 13/16 x 1/16 (2)	
6702	WASHER, 5/16 x 11/16 x 1/16 (8)	
6703	WASHER, 1/4 x 5/8 x 1/16 (2)	
7039	LOCKWASHER, 7/16 (3)	
7041	LOCKWASHER, 5/16 (16)	
7686	LOCKNUT, 1/4-20 x 5/16 x 7/16 hex. (2)	
7748W	NUT, 5/16-18 x 1/4 x 1/2 hex. (16)	
7775	LOCKNUT, 3/8-24 x 7/16 x 9/16 hex. (2)	
10006	CABLE STRAP	
40453-78	ACCELERATOR PEDAL ASSEMBLY	
41528-78	BRACKET, brake cable stop	
41531-78	SPRING DAMPER, brake cable	
41537-78	SPRING, extension – damper (2)	
41538-78	CLEVIS PIN, spring damper (2)	
42600-78	BRAKE CALIPER AND CABLE	
42602-78	BUMPER PAD, brake pedal	
42629-78	CABLE GUIDE	
42633-78	BRACKET, brake support	
42642-78	BRAKE PEDAL ASSEMBLY	
43803-78	REINFORCEMENT, upper	
43808-78	REINFORCEMENT, lower	
47781-78	BRAKE DISC AND HUB	
83190-75	STRAIGHT KEY, traction motor	

NOTE: Asterisk (*) indicates part is used for latest model year shown on cover.

STEERING WHEEL AND GEAR OLD STYLE

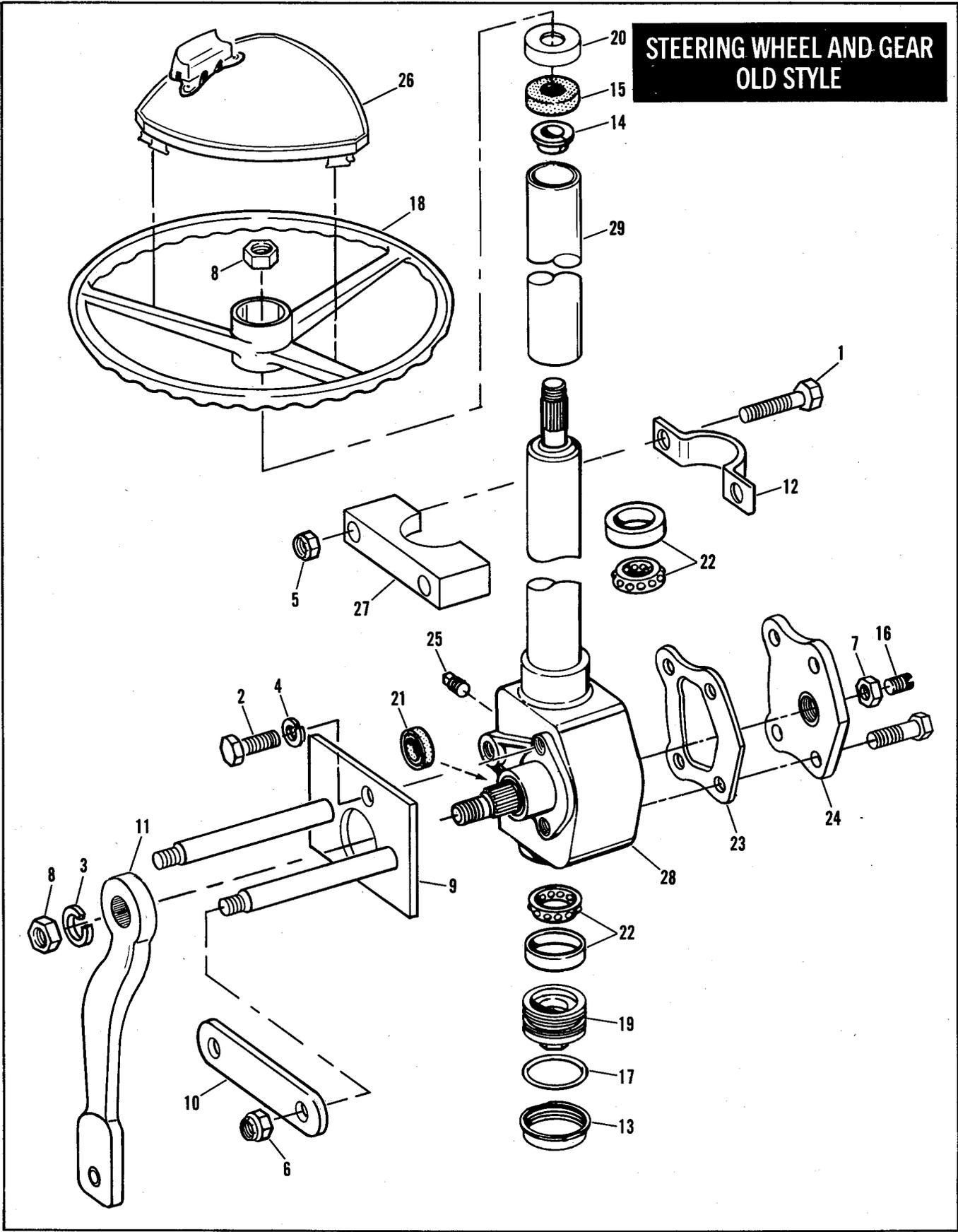

STEERING WHEEL AND GEAR - OLD STYLE

INDEX NO.	PART NO.	NAME	USED ON
-----------	----------	------	---------

NOTE: For greater service reliability, we recommend updating your vehicle with the improvement parts listed on the next page.

1	3454	BOLT, 1/4-20 x 1-3/4 hex. hd. (2).....	76 & 77 - DE40
2	3858	BOLT, 7/16-14 x 7/8 hex. hd. (3).....	76 & 77 - DE40
3	7022	LOCKWASHER, 5/8.....	76 & 77 - DE40
4	7039	LOCKWASHER, 7/16 (3).....	76 & 77 - DE40
5	7686	LOCKNUT, 1/4-20 x 5/16 x 7/16 hex. (2).....	76 & 77 - DE40
6	7775	LOCKNUT, 3/8-24 x 7/16 x 9/16 hex. (2).....	76 & 77 - DE40
7	7845	LOCKNUT, 1/2-20 x 7/16 x 3/4 hex.....	76 & 77 - DE40
8	7995	NUT, 5/8-18 x 3/8 x 15/16 (2).....	76 & 77 - DE40
9	43820-75A	STEERING STOP.....	76 & 77 - DE40
10	43823-75	PLATE, steering stop.....	76 & 77 - DE40
11	47585-75A	ARM, steering gear.....	76 & 77 - DE40
12	47596-75	CLAMP, steering column support block.....	76 & 77 - DE40
13	57066-68	LOCKNUT, steering gear end cap.....	76 & 77 - DE40
14	57067-68	NYLON BUSHING, steering shaft.....	76 & 77 - DE40
15	57070-68	DUST SEAL.....	76 & 77 - DE40
16	57071-68	ADJUSTING SCREW, steering worm gear.....	76 & 77 - DE40
17	57074-68	SEAL, end cap.....	76 & 77 - DE40
18	57075-69	STEERING WHEEL, black.....	76 & 77 - DE40
19	57076-68	END CAP.....	76 & 77 - DE40
20	57077-67	DUST COVER, steering gear.....	76 & 77 - DE40
21	57081-67	OIL SEAL, steering shaft.....	76 & 77 - DE40
22	57082-67	SET OF TWO BEARINGS AND CUPS, worm shaft.....	76 & 77 - DE40
23	57084-67	GASKET, side cover.....	76 & 77 - DE40
24	57088-67	SIDE COVER.....	76 & 77 - DE40
25	57090-67	FILLER PLUG.....	76 & 77 - DE40
26	57098-75	CARD HOLDER ASSEMBLY.....	76 & 77 - DE40
27	57135-75A	SUPPORT BLOCK, steering column.....	76 & 77 - DE40
28	57226-75	STEERING GEAR ASSEMBLY.....	76 & 77 - DE40
29	57227-75A	SHELL, steering column.....	76 & 77 - DE40

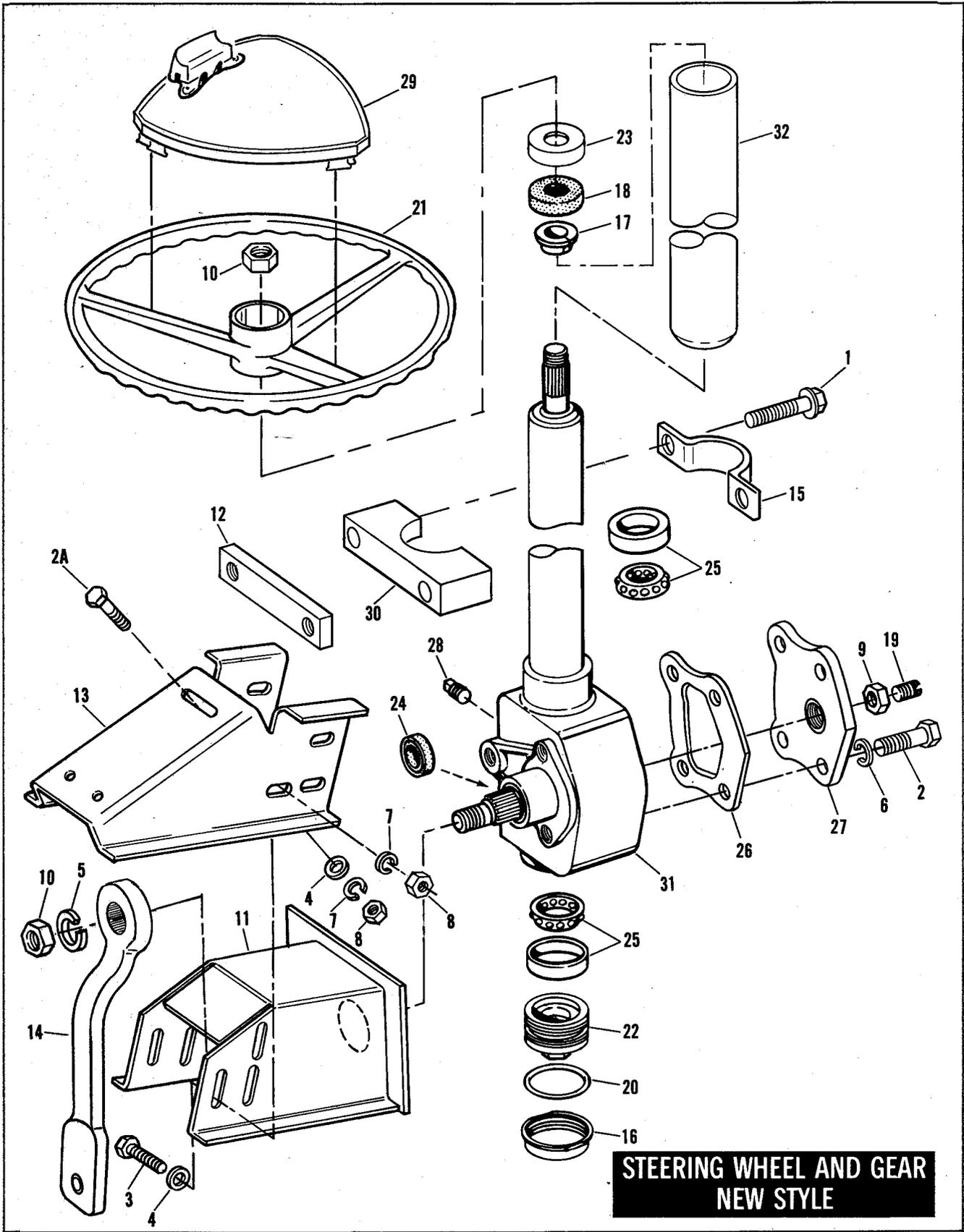

STEERING WHEEL AND GEAR – NEW STYLE

INDEX NO.	PART NO.	N A M E	USED ON
1	3783	BOLT, 1/4-20 x 1-3/4 hex. washer hd. (2)	76 to * – DE40
2	3854	BOLT, 7/16-14 x 1 hex. hd. (3)	76 to * – DE40
2A	3987	BOLT, 5/16-18 x 3/4 hex. hd. (3)	76 to * – DE40
3	3991	BOLT, 5/16-18 x 7/8 hex. hd. (6)	76 to * – DE40
4	6702	WASHER, 5/16 x 11/16 x 1/16 (9)	76 to * – DE40
5	7022	LOCKWASHER, 5/8	76 to * – DE40
6	7039	LOCKWASHER, 7/16 (3)	76 to * – DE40
7	7041	LOCKWASHER, 5/16 (9)	76 to * – DE40
8	7748W	NUT, 5/16-18 x 1/4 x 1/2 hex. (9)	76 to * – DE40
9	7845	LOCKNUT, 1/2-20 x 7/16 x 3/4 hex.	76 to * – DE40
10	7995	NUT, 5/8-18 x 3/8 x 15/16 hex. (2)	76 to * – DE40
11	43803-78	REINFORCEMENT, steering shaft – upper	76 & 77 – DE40
12	43805-78	LOCK PLATE, support block	76 to * – DE40
13	43808-78	REINFORCEMENT, steering shaft – lower	76 to * – DE40
14	47585-75A	ARM, steering gear	76 to * – DE40
15	47596-75	CLAMP, steering column support block	76 to * – DE40
16	57066-68	LOCKNUT, steering gear end cap	76 to * – DE40
17	57067-68	NYLON BUSHING, steering shaft	76 to * – DE40
18	57070-68	DUST SEAL	76 to * – DE40
19	57071-68	ADJUSTING SCREW, steering worm gear	76 to * – DE40
20	57074-68	SEAL, end cap	76 to * – DE40
21	57075-69	STEERING WHEEL, black	76 to * – DE40
22	57076-68	END CAP	76 to * – DE40
23	57077-67	DUST COVER, steering gear	76 to * – DE40
24	57081-67	OIL SEAL, steering shaft	76 to * – DE40
25	57082-67	SET OF TWO BEARINGS AND CUPS, worm shaft	76 to * – DE40
26	57084-67	GASKET, side cover	76 to * – DE40
27	57088-67	SIDE COVER	76 to * – DE40
28	57090-67	FILLER PLUG	76 to * – DE40
29	57098-75	CARD HOLDER ASSEMBLY	76 to * – DE40
30	57135-75A	SUPPORT BLOCK, steering column	76 to * – DE40
31	57226-75	STEERING GEAR ASSEMBLY	76 to * – DE40
32	57227-75A	SHELL, steering column	76 to * – DE40

NOTE: For increased reliability, 1976 and 1977 models should be updated to 1978 vehicle specifications by installing the following Kit:

57053-78	STEERING GEAR KIT	76 to * – DE40
	Consists of:	
	3783 BOLT, 1/4-20 x 1-3/4 hex. washer hd. (2)	
	43805-78 LOCKPLATE	
	57135-75A SUPPORT BLOCK	

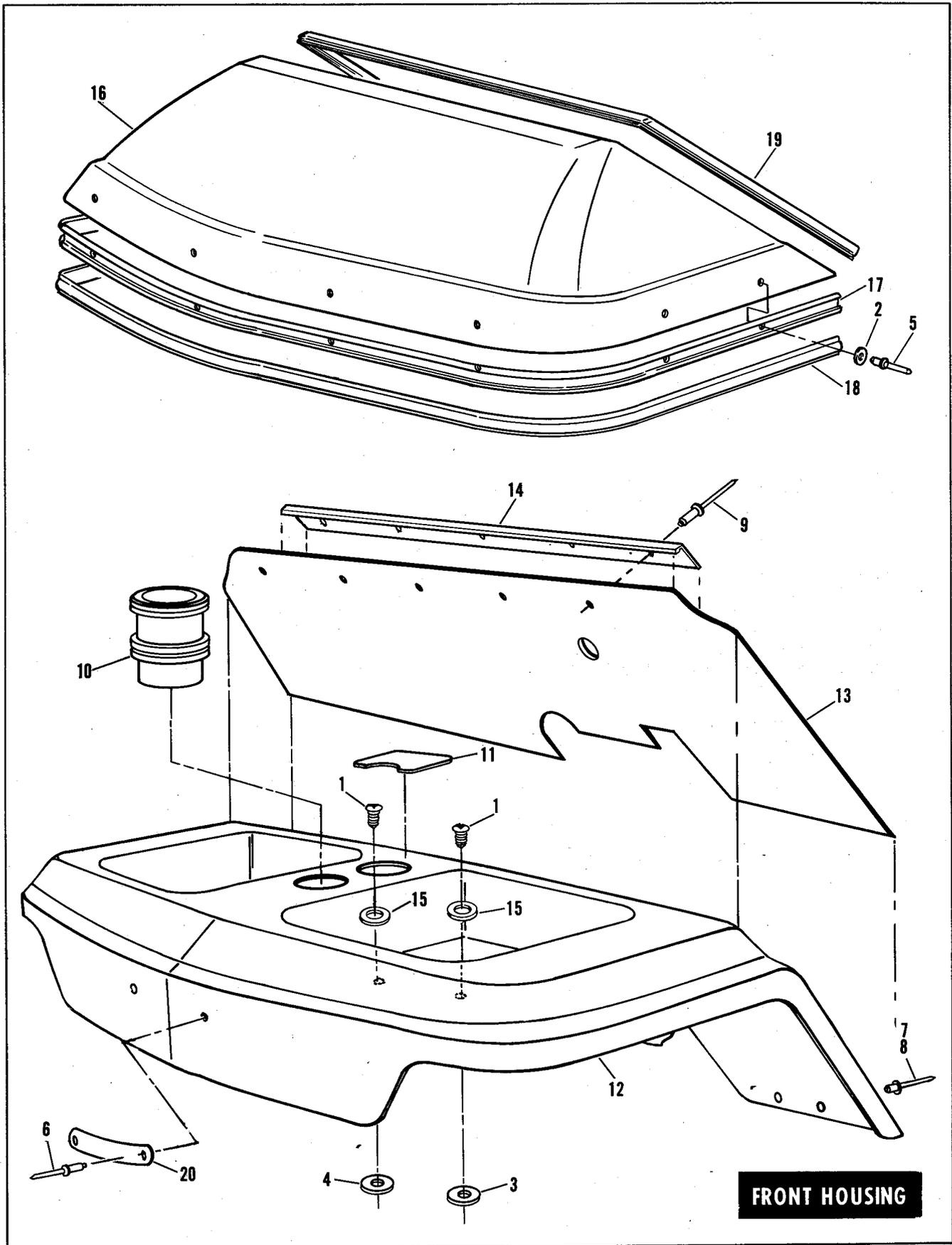

FRONT HOUSING

INDEX PART		NAME	USED ON
NO.	NO.		
1	2745	SCREW, 1/4-20 x 3/4 self tapping truss hd. (4)	76 to * - DE40
2	6150W	WASHER, 3/16 x 3/8 x 1/16 (8)	76 to * - DE40
3	7415	RUBBER WASHER, 3/8 x 1-1/8 x 1/8 (2)	76 to * - DE40
4	7416	RUBBER WASHER, 5/16 x 1-3/8 x 9/32 (2)	76 to * - DE40
5	8212	POP RIVET (8)	76 to * - DE40
6	8321	POP RIVET, 1/8 x 1/2 x 1/4 dia. hd. (2)	76 to * - DE40
7	8480	POP RIVET, 3/16 x 1/2 x 5/8 dia. hd. (black aluminum) (13)	Late 76 to * - DE40
8	8488B	POP RIVET, 3/16 x 3/8 x 5/8 dia. hd. (black) (13)	Early 76 - DE40
9	8641B	POP RIVET, 3/16 x 5/8 x 3/8 dia. hd. (black) (5)	76 to * - DE40
10	31422-72	BEVERAGE HOLDER CUP (2)	76 to * - DE40
11	47464-76	CAUTION DECAL	76 to * - DE40
12	50210-75	FRONT HOUSING	76 to * - DE40
13	50701-75A	FLOORMAT	76 to * - DE40
14	50703-75	MOULDING, floormat	76 to * - DE40
15	53240-72	WASHER (4)	76 to * - DE40
16	58510-76	SHIELD KIT, front housing	76 & 77 - DE40
17	58511-76	CHANNEL, trim	76 to * - DE40
18	58512-76	TRIM, channel	76 to * - DE40
19	58513-76	TRIM, shield edge	76 to * - DE40
20	61771-72	NAMEPLATE	76 to * - DE40

NOTE: Asterisk (*) indicates part is used for latest model year shown on cover.

FRAME, REAR SUSPENSION AND BUMPERS

FRONT

REAR

BRAKE KIT COMPONENTS

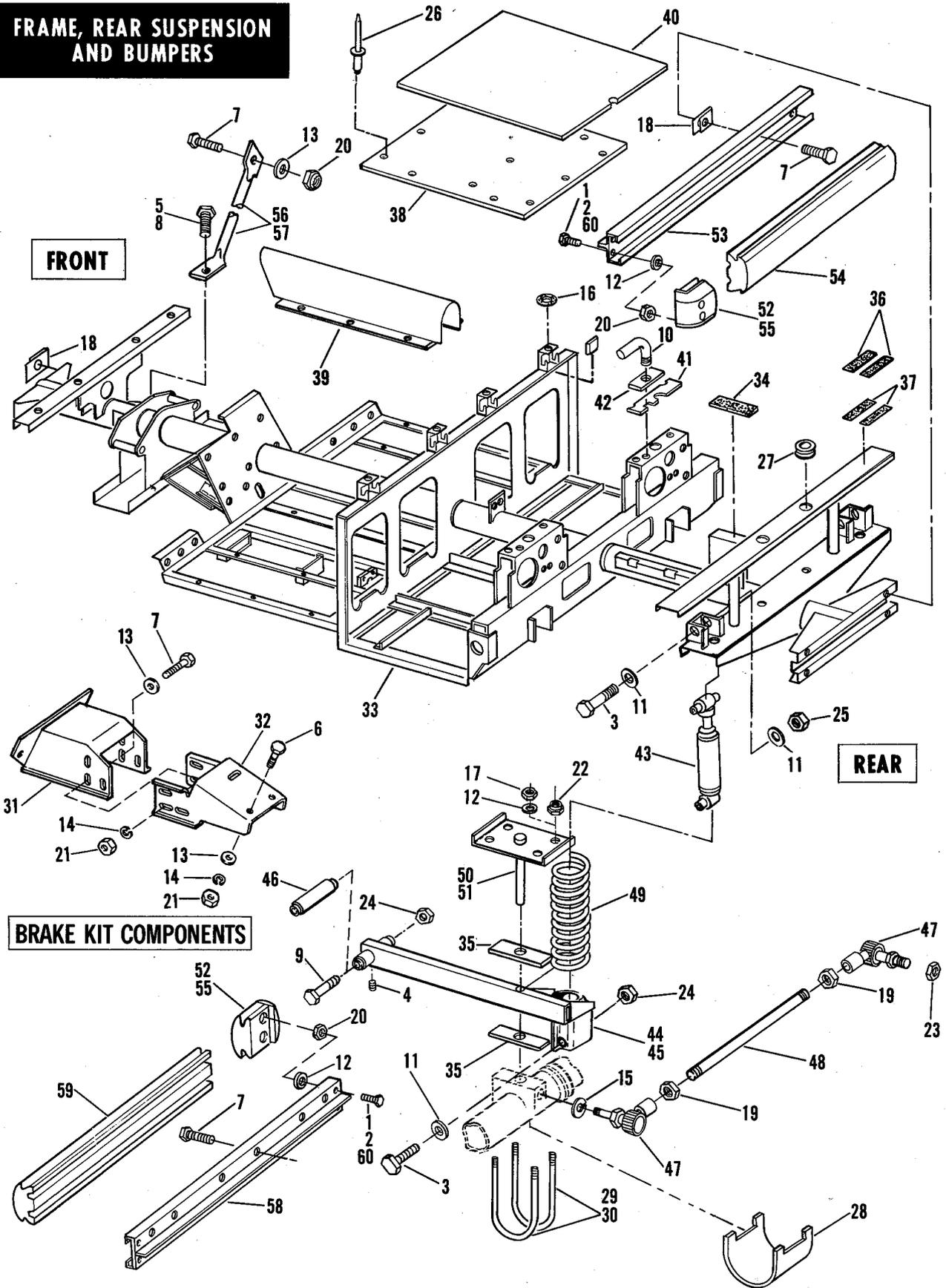

FRAME, REAR SUSPENSION AND BUMPERS

INDEX NO.	PART NO.	N A M E	U S E D O N
1	2004	SCREW, 3/8-16 x 2 pan hd. (8)	78 to * - DE40
2	2778	SCREW, No. 10-16 x 1-1/2 self tapping hex. washer hd. (8).	Late 76 & 77 - DE40
3	2870W	BOLT, 7/16-14 x 3 hex. hd. (4)	76 to * - DE40
4	3236B	SET SCREW, 1/4-20 x 1/2 socket hd. (2)	76 to * - DE40
5	3953W	BOLT, 5/16-24 x 1/2 hex. hd. (8)	Early 76 - DE40
6	3987	BOLT, 5/16-18 x 3/4 hex. hd. (3)	76 to * - DE40
7	3991	BOLT, 5/16-18 x 7/8 hex. hd. (16)	76 to * - DE40
8	3996	BOLT, 5/16-24 x 7/8 hex. hd. (2)	Late 76 to * - DE40
9	4253	BOLT, 7/16-20 x 3-1/2 hex. hd. (2)	76 to * - DE40
10	5230	SCREW PIN, 1/4-28 x 7/8 seat hold-down (2)	76 - DE40
11	6334	WASHER, 7/16 x 15/16 x 1/16 (8)	76 to * - DE40
12	6701	WASHER, 3/8 x 13/16 x 1/16 (8) (8 - u-bolt - Late 76 & 77 only)	Late 76 to * - DE40
13	6702	WASHER, 5/16 x 11/16 x 1/16 (17) (11 - Late 76 & later)	76 to * - DE40
14	7041	LOCKWASHER, 5/16 (9)	76 to * - DE40
15	7068	LOCKWASHER, 1/2	76 to * - DE40
16	7415	RUBBER WASHER, 3/8 x 1-1/8 x 1/8 (4)	76 to * - DE40
17	7506	LOCKNUT, 3/8-24 x 3/8 x 9/16 hex. (8)	Late 76 & 77 - DE40
18	7632	SPEED NUT, bumpers (8)	76 to * - DE40
19	7644	JAM NUT, 1/2-20 x 5/16 x 3/4 hex. (2)	76 to * - DE40
20	7739	LOCKNUT, 5/16-18 x 11/32 x 1/2 hex. (8) (2 - Late 76 & 77) (10 - 78 & later)	76 to * - DE40
21	7748W	NUT, 5/16-18 x 1/4 x 1/2 hex. (9)	76 to * - DE40
22	7775	LOCKNUT, 3/8-24 x 7/16 x 9/16 hex. (8)	Early 76; 78 to * - DE40
23	7812W	LOCKNUT, 1/2-20 x 5/16 x 3/4 hex.	76 to * - DE40
24	7825	LOCKNUT, 7/16-20 x 7/16 x 5/8 hex. (2)	Late 76 to * - DE40
25	7827W	LOCKNUT, 7/16-14 x 7/16 x 5/8 hex. (6) (4 - Late 76 & later)	76 to * - DE40
26	8641B	POP RIVET, 3/16 x 5/8 x 3/8 dia. hd. (black) (26)	76 to * - DE40
27	11422	GROMMET, bag holder to body and frame (4)	76 to * - DE40
28	41565-77	MOUNTING SHIM, u-bolt (2)	77 - DE40
29	41783-75	U-BOLT, swing arm (4)	76; 78 to * - DE40
30	41783-77	U-BOLT, swing arm (4)	77 - DE40
31	43803-78	STEERING SHAFT REINFORCEMENT, upper (Brake Kit)	76 & 77 - DE40
32	43808-78	STEERING SHAFT REINFORCEMENT, lower (Brake Kit)	76 & 77 - DE40
33	47099-77B	FRAME	76 to * - DE40
34	47403-75	PAD, body support	76 to * - DE40
35	47437-75	PAD, u-bolt bracket (4)	76 to * - DE40
36	50226-75	HOOK PAD, body mounting (4)	76 to * - DE40
37	50227-75	LOOP PAD, body mounting (4)	76 to * - DE40
38	50578-75	FLOORBOARD (2)	76 to * - DE40
39	50700-75	FLOOR TUNNEL	76 to * - DE40
40	50702-75A	FLOORMAT (2)	76 to * - DE40
41	52069-75A	PAD, seat and body mounting (4) (2 - 78 & later)	76 to * - DE40
42	52408-78	PAD, seat and body mount (4)	78 to * - DE40
43	54585-75	SHOCK ABSORBER (2)	76 to * - DE40
44	54586-75	SWING ARM, right	76 to * - DE40
45	54587-75	SWING ARM, left	76 to * - DE40
46	54595-75	BUSHING, swing arm (2)	76 to * - DE40
47	54598-75	END, sway bar (2)	76 to * - DE40
48	54599-75	ROD, sway bar	76 to * - DE40
49	54640-75	SPRING (2)	76 to * - DE40
50	82852-75	BRACKET, u-bolt (2)	76; 78 to * - DE40
51	82852-77	BRACKET, u-bolt (2)	77 - DE40
52	91015-75	END CAP, bumper channels (4)	76 & 77 - DE40
53	91025-75A	CHANNEL, rear bumper	76 to * - DE40
54	91026-75	RUBBER INSERT, rear bumper channel	76 to * - DE40
55	91035-78	END CAP, bumper channel (4)	78 to * - DE40
56	91102-75	SUPPORT, front bumper (2)	Early 76 - DE40
57	91102-76	SUPPORT, front bumper (2)	Late 76 to * - DE40
58	91115-75A	CHANNEL, front bumper	76 to * - DE40
59	91116-75	RUBBER INSERT, front bumper channel	76 to * - DE40
60	95671-42	SCREW, No. 10 x 1-1/2 self tapping pan hd. (8)	Early 76 - DE40

NOTE: Asterisk (*) indicates part is used for latest model year shown on cover.

SEAT BRAKE

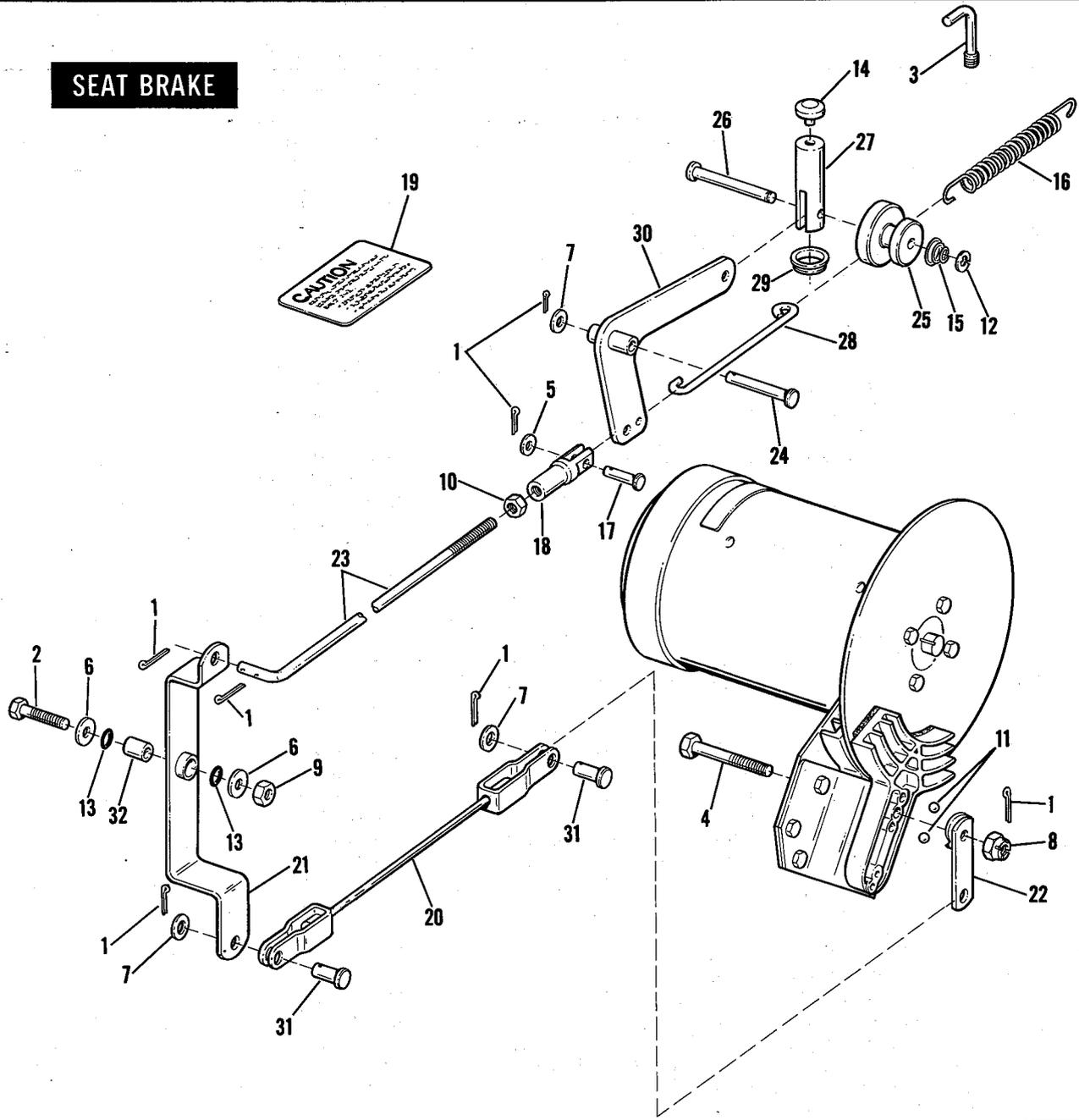

SEAT BRAKE

INDEX PART		NAME	USED ON
NO.	NO.		
1	515	COTTER PIN, 1/16 dia. x 1/2 (7)	Late 76 & 77 - DE40
2	2818	BOLT, 5/16-18 x 1-1/2 hex. hd.	Late 76 & 77 - DE40
3	4254	SCREW, "L" shape, 5/16-24 x 1-7/8 (2)	Late 76 & 77 - DE40
4	4270	BOLT, 5/16-24 x 4-1/2 hex. hd. (drilled thread end)	Late 76 & 77 - DE40
5	6220W	WASHER, 1/4 x 7/16 x 1/32	Late 76 & 77 - DE40
6	6333	WASHER, 5/16 x 7/8 x 5/64 (2)	Late 76 & 77 - DE40
7	6375B	WASHER, 3/8 x 9/16 x 1/32 (3)	Late 76 & 77 - DE40
8	7728	CASTLE NUT, 5/16-24 x 15/32 x 1/2 hex.	Late 76 & 77 - DE40
9	7740	LOCKNUT, 5/16-18 x 1/4 x 1/2 hex.	Late 76 & 77 - DE40
10	7753	NUT, 5/16-24 x 1/4 x 1/2 hex.	Late 76 & 77 - DE40
11	8858	BALL, cam lever (2)	Late 76 & 77 - DE40
12	11015	RETAINING RING, lockout knob	Late 76 & 77 - DE40
13	11105	O-RING, rod lever (2)	Late 76 & 77 - DE40
14	26814-67	CONTACT BUTTON, plunger plate	Late 76 & 77 - DE40
15	27291-32	SPRING, lockout knob	Late 76 & 77 - DE40
	41621-76	DISC BRAKE ASSEMBLY (seat brake)	Late 76 & 77 - DE40
16	41834-67	SPRING, plunger arm (2)	Late 76 & 77 - DE40
17	42269-30	CLEVIS PIN, plunger arm rod	Late 76 & 77 - DE40
18	42330-71	CLEVIS, rod end	Late 76 & 77 - DE40
19	52056-72A	CAUTION LABEL	Late 76 & 77 - DE40
20	52311-76	CABLE, rod lever to brake cam	Late 76 & 77 - DE40
21	52313-76	LEVER, rod and brake cable	Late 76 & 77 - DE40
22	52315-76	CAM, disc brake	Late 76 & 77 - DE40
23	52317-76	ROD, plunger arm	Late 76 & 77 - DE40
24	52319-76	CLEVIS PIN, plunger arm	Late 76 & 77 - DE40
25	52320-76	KNOB, lockout	Late 76 & 77 - DE40
26	52321-76	CLEVIS PIN, lockout knob	Late 76 & 77 - DE40
27	52322-76	PLUNGER PIN	Late 76 & 77 - DE40
28	52323-76	ROD, plunger arm spring	Late 76 & 77 - DE40
29	52324-76	BUSHING, plunger	Late 76 & 77 - DE40
30	52325-76	PLUNGER ARM	Late 76 & 77 - DE40
	52327-76	SEAT BRAKE KIT	Late 76 & 77 - DE40
31	73092-61B	CLEVIS PIN, brake cable (2)	Late 76 & 77 - DE40
32	89465-74	SPACER, rod lever bolt	Late 76 & 77 - DE40

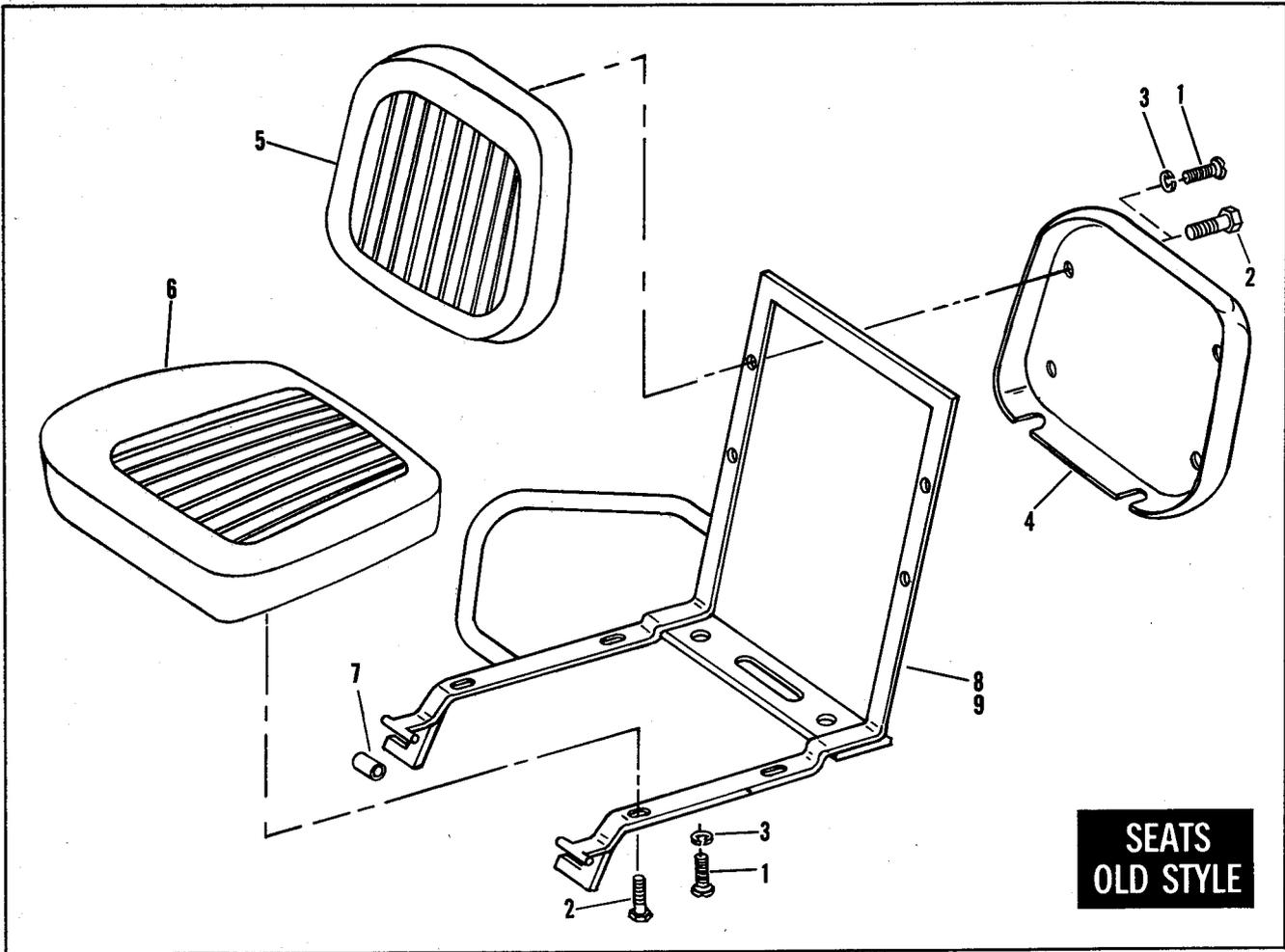

SEATS – OLD STYLE

INDEX NO.	PART NO.	N A M E	U S E D O N
--------------	-------------	---------	-------------

NOTE: For greater service reliability, we recommend updating your vehicle with the improvement parts listed on the next page.

1	2605	SCREW, 5/16-18 x 1-3/4 Pozidriv pan hd. (16).....	Early 76 – DE40
2	3987	BOLT, 5/16-18 x 3/4 hex. hd. (16)	Late 76 & 77 – DE40
3	7041	LOCKWASHER, 5/16 (8).....	Early 76 – DE40
4	52048-75	COVER, seat back pad (2)	Early 76 – DE40
	52048-76	COVER, seat back pad (2)	Late 76 & 77 – DE40
5	52191-75	SEAT BACK PAD (2).....	Early 76 – DE40
	52191-76	SEAT BACK PAD (2).....	Late 76 & 77 – DE40
6	52193-75	SEAT CUSHION (2).....	Early 76 – DE40
	52193-76	SEAT CUSHION (2).....	Late 76 & 77 – DE40
7	52221-76	PAD (4).....	76 & 77 – DE40
8	52670-75	SEAT SUPPORT WITH HANDRAIL, right	Early 76 – DE40
	52670-76	SEAT SUPPORT WITH HANDRAIL, right	Late 76 & 77 – DE40
9	52672-75	SEAT SUPPORT WITH HANDRAIL, left	Early 76 – DE40
	52672-76	SEAT SUPPORT WITH HANDRAIL – left	Late 76 & 77 – DE40

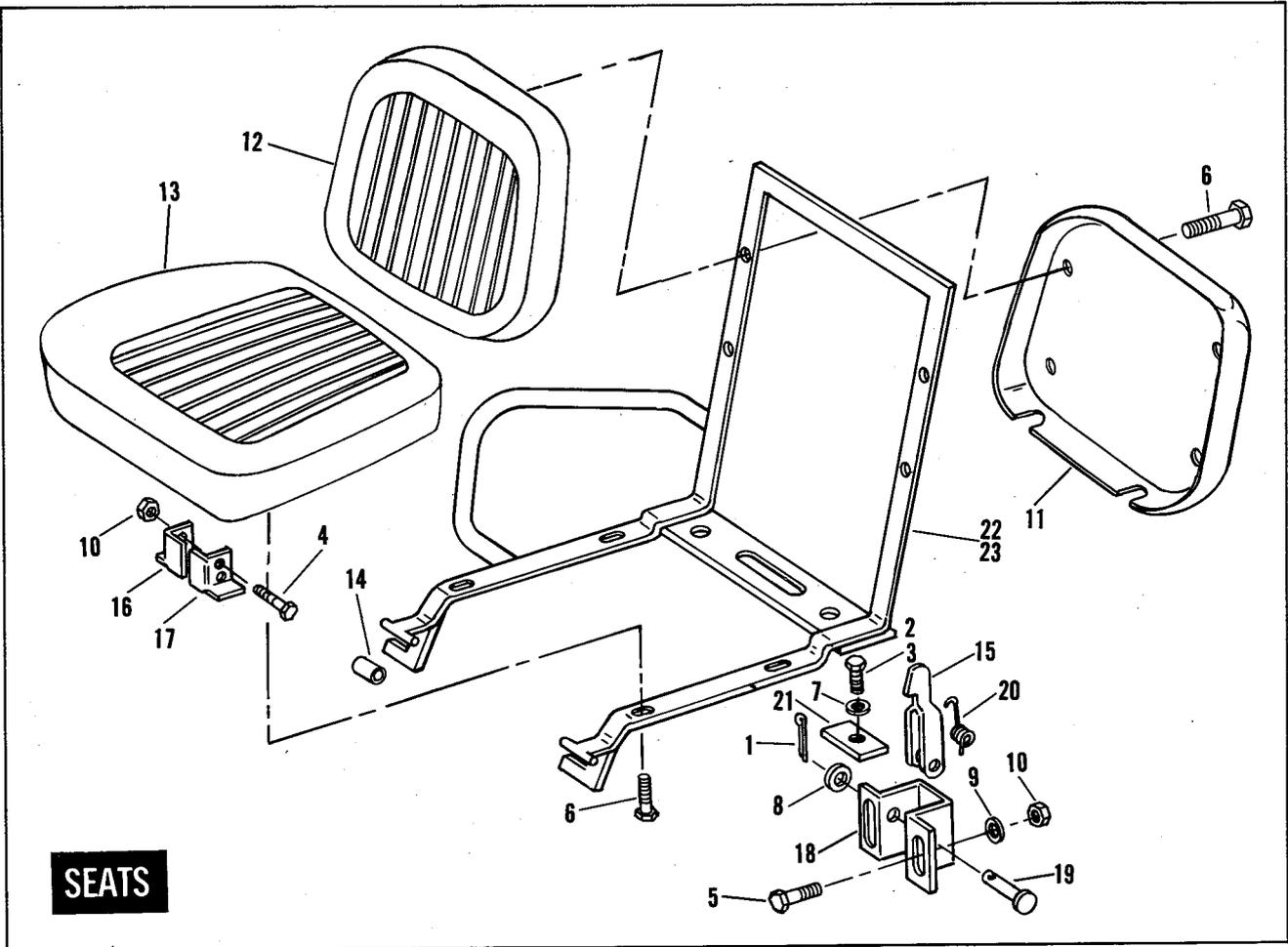

SEATS – NEW STYLE

INDEX NO.	PART NO.	N A M E	U S E D O N
1	559	COTTER PIN, 1/8 dia. x 1-1/4 (2).....	76 to * – DE40
2	2500	SCREW, 1/4-20 x 1 Pozidriv truss hd. (4).....	78 to * – DE40
3	2577	SCREW, 1/4-20 x 7/8 Pozidriv pan hd. (4).....	76 & 77 – DE40
4	2821	BOLT, 1/4-20 x 2-1/4 hex. hd. (4).....	76 to * – DE40
5	3787	BOLT, 1/4-20 x 3/4 hex. hd. (4).....	76 to * – DE40
6	3978	BOLT, 5/16-18 x 3/4 hex. hd. (16).....	Late 76 to * – DE40
7	6253W	WASHER, 1/4 x 3/4 x 1/16 (4).....	76 to * – DE40
8	6701	WASHER, 3/8 x 13/16 x 1/16 (2).....	76 to * – DE40
9	6703	WASHER, 1/4 x 5/8 x 1/16 (4).....	76 to * – DE40
10	7686	LOCKNUT, 1/4-20 x 5/16 x 7/16 hex. (8).....	76 to * – DE40
11	52048-76	COVER, seat back pad (2).....	Late 76 to * – DE40
12	52191-76	SEAT BACK PAD (2).....	Late 76 to * – DE40
13	52193-76	SEAT CUSHION (2).....	Late 76 to * – DE40
14	52221-76	PAD (4).....	76 to * – DE40
15	52402-78	SEAT LOCK (2).....	76 to * – DE40
16	52403-78	BRACKET, seat front – left (4).....	76 to * – DE40
17	52404-78	BRACKET, seat front – right (4).....	76 to * – DE40
18	52405-78	BRACKET, seat lock (2).....	76 to * – DE40
19	52406-78	CLEVIS PIN, seat lock (2).....	76 to * – DE40
20	52407-78	SPRING, seat lock (2).....	76 to * – DE40
21	52408-78	PAD, seat (4).....	76 to * – DE40
22	52670-76	SEAT SUPPORT WITH HANDRAIL, right.....	Late 76 to * – DE40
23	52672-76	SEAT SUPPORT WITH HANDRAIL, left.....	Late 76 to * – DE40

NOTE: For increased reliability, 1976 and 1977 models should be updated to 1978 vehicle specifications by installing the following Kit:

52451-78	SEAT LOCK KIT, front and rear (2).....	76 to * – DE40
	Consists of:	
559	COTTER PIN, 1/8 dia. x 1-1/4	
2577	SCREW, 1/4-20 x 7/8 Pozidriv pan hd. (2)	
2821	BOLT, 1/4-20 x 2-1/4 hex. hd. (2)	
3787	BOLT, 1/4-20 x 3/4 hex. hd. (2)	
6253W	WASHER, 1/4 x 3/4 x 1/16 (2)	
6701	WASHER, 3/8 x 13/16 x 1/16	
6703	WASHER, 1/4 x 5/8 x 1/16 (2)	
7686	LOCKNUT, 1/4-20 x 5/16 x 7/16 hex. (4)	
52402-78	SEAT LOCK	
52403-78	BRACKET, seat front – left (2)	
52404-78	BRACKET, seat front – right (2)	
52405-78	BRACKET, seat lock	
52406-78	CLEVIS PIN, seat lock	
52407-78	SPRING, seat lock	
52408-78	PAD, seat (2)	

NOTE: Asterisk (*) indicates part is used for latest model year shown on cover.

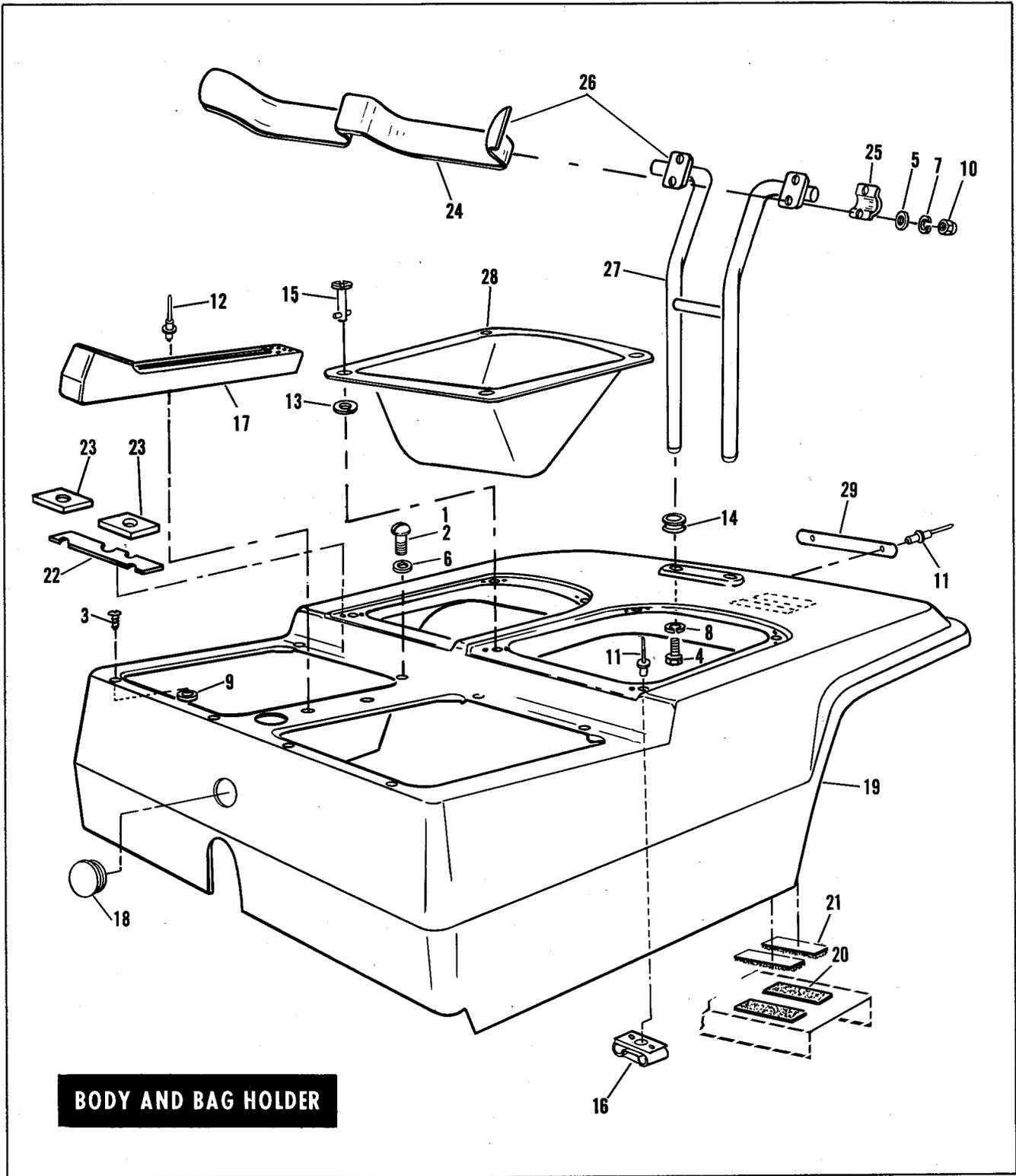

BODY AND BAG HOLDER

BODY AND BAG HOLDER

INDEX NO.	PART NO.	NAME	USED ON
1	2500	SCREW, 1/4-20 x 1 Pozidriv truss hd. (4).....	78 to * - DE40
2	2577	SCREW, 1/4-20 x 7/8 Pozidriv pan hd. (4).....	76 & 77 - DE40
3	2745	SCREW, 1/4-20 x 3/4 self tapping Pozidriv truss hd. (4)....	76 to * - DE40
4	3974HW	BOLT, 5/16-24 x 3/4 hex. hd. (2).....	76 to * - DE40
5	6228W	WASHER, 1/4 x 1/2 x 1/16 (4).....	Early 76 - DE40
6	6253W	WASHER, 1/4 x 3/4 x 1/16 (4).....	76 to * - DE40
7	7036	LOCKWASHER, 1/4 (4).....	76 to * - DE40
8	7041	LOCKWASHER, 5/16 (2).....	76 to * - DE40
9	7415	RUBBER WASHER, 3/8 x 1-1/8 x 1/8 (4).....	76 to * - DE40
10	7737W	ACORN NUT, 1/4-20 x 15/32 x 7/16 hex. (4).....	76 to * - DE40
11	8321	POP RIVET, 1/8 x 1/2 x 1/4 dia. hd. (aluminum) (16).....	76 to * - DE40
12	8685	POP RIVET, 3/16 x 1/2 x 3/8 dia. hd. (18).....	76 to * - DE40
13	11085	RETAINER WASHER, bag well stud (8).....	76 to * - DE40
14	11422	GROMMET, bag holder to body and frame (4).....	76 to * - DE40
15	11702	STUD, bag well (8).....	76 to * - DE40
16	11703	RECEPTACLE, bag well stud (8).....	76 to * - DE40
17	31431-75A	TEE & GOLF BALL HOLDER.....	76 to * - DE40
18	50212-77	GROMMET, body - front.....	77 to * - DE40
19	50213-78	BODY, without charger plug.....	76 to * - DE40
20	50226-75	HOOK PAD, body mounting (4).....	76 to * - DE40
21	50227-75	LOOP PAD, body mounting (4).....	76 to * - DE40
22	52069-75A	PAD, seat and body mounting (2 - 78 & later).....	76 to * - DE40
23	52408-78	PAD, seat mounting (4).....	76 to * - DE40
24	53470-71	BAG CARRIER.....	76 to * - DE40
25	53498-71	BRACKET, bag carrier (2).....	76 to * - DE40
26	53500-75	BAG HOLDER, complete.....	76 to * - DE40
27	53501-75A	SUPPORT TUBE ASSEMBLY.....	76 to * - DE40
28	53574-75	BAG WELL (2).....	76 to * - DE40
29	61771-72	NAMEPLATE.....	76 to * - DE40

NOTE: Asterisk (*) indicates part is used for latest model year shown on cover.

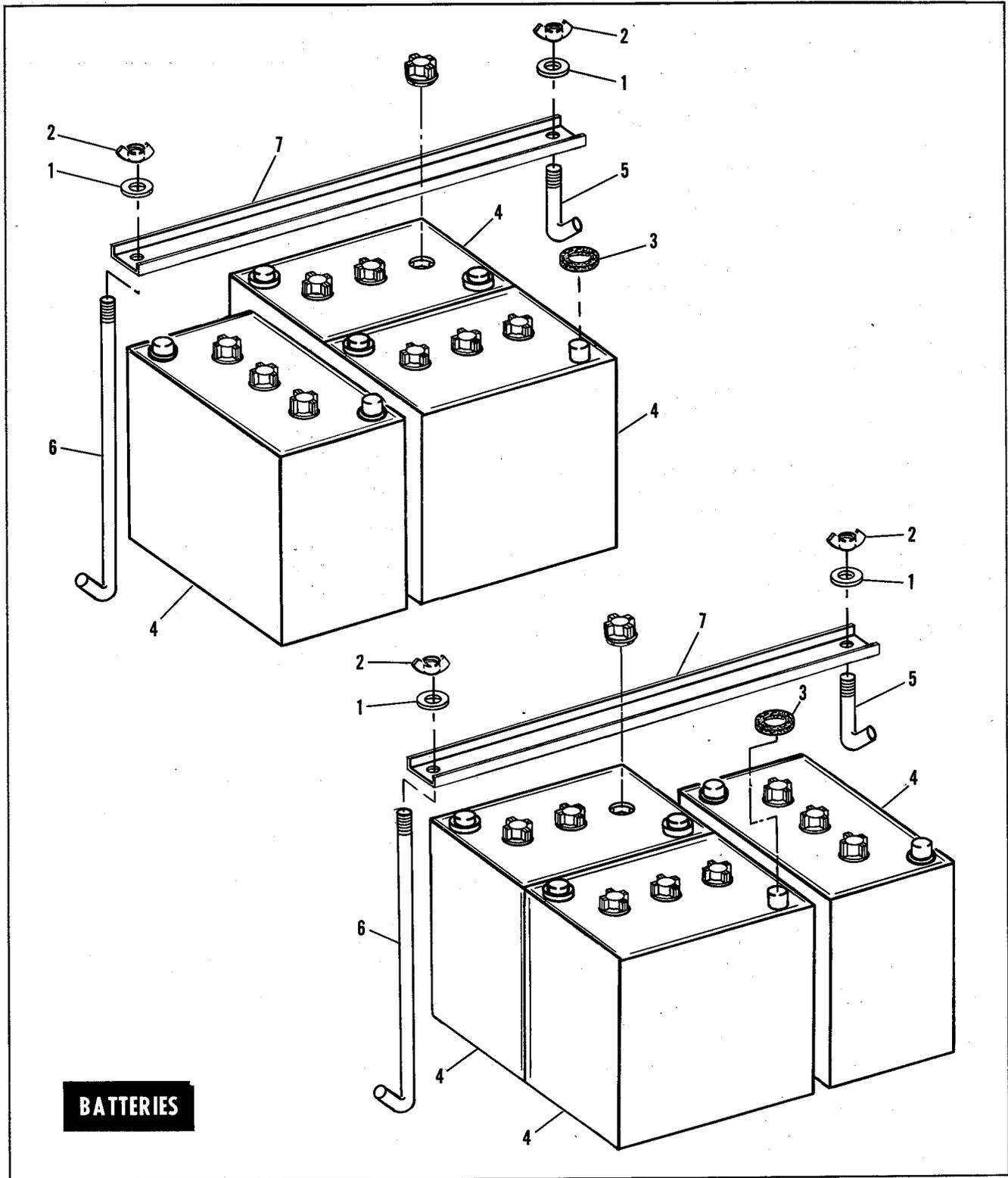

BATTERIES

BATTERIES

INDEX NO.	PART NO.	N A M E	U S E D O N
1	6703	WASHER, 1/4 x 5/8 x 1/16 (4).....	76 to * - DE40
2	8119W	WING NUT, 1/4-20 (4).....	76 to * - DE40
3	43733-47	FELT WASHER (12).....	76 to * - DE40
4	66007-63	BATTERY, dry (6).....	76 to * - DE40
5	66560-75	ROD, battery hold-down - 2" (2).....	76 to * - DE40
6	66561-75	ROD, battery hold-down - 11" (2).....	76 to * - DE40
7	66564-75	CHANNEL, battery hold-down (2).....	76 to * - DE40

NOTE: Asterisk (*) indicates part is used for latest model year shown on cover.

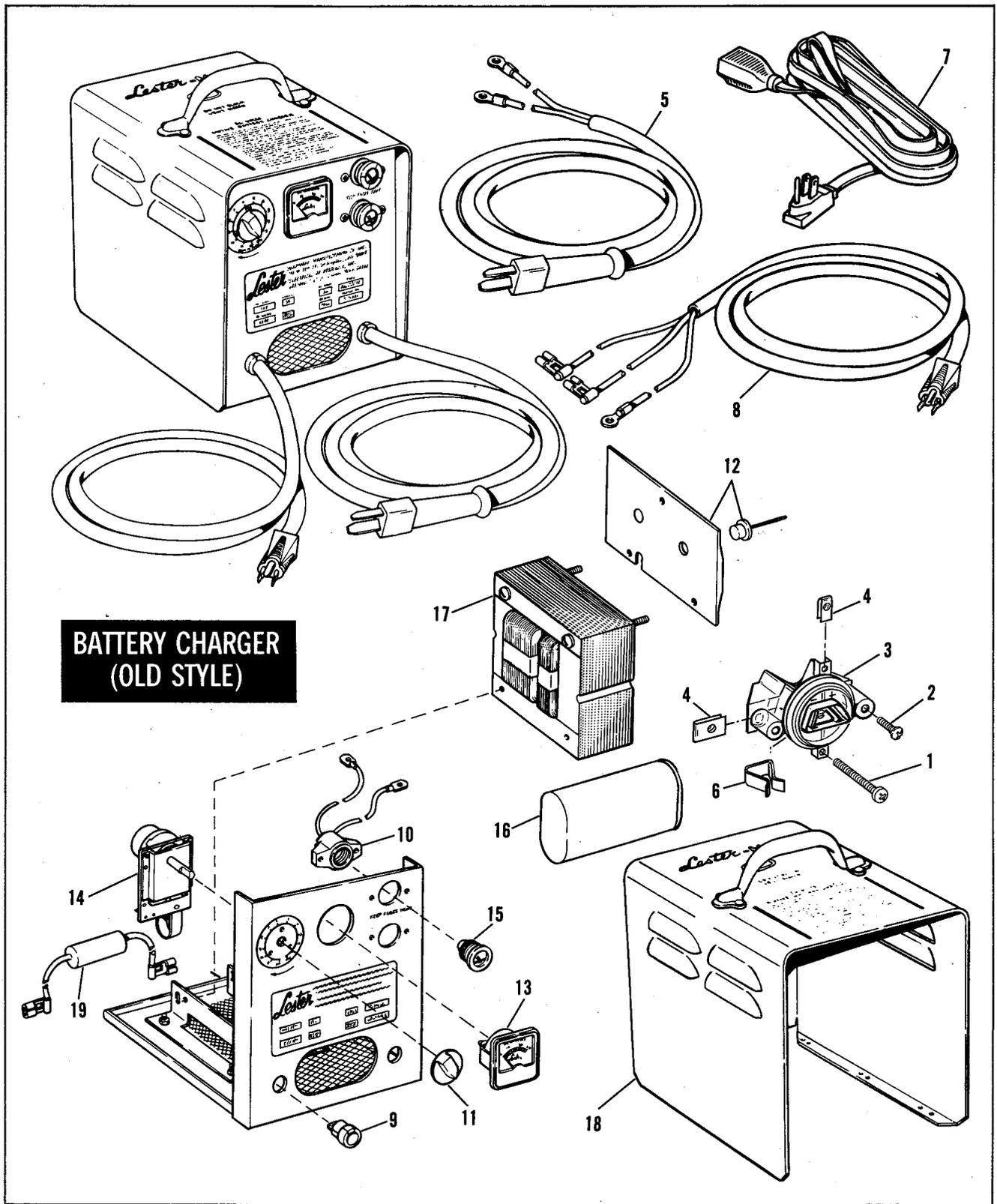

**BATTERY CHARGER
(OLD STYLE)**

BATTERY CHARGER (OLD STYLE)

INDEX NO.	PART NO.	N A M E	USED ON
1	2807	SCREW, No. 8-32 x 1-1/2 Pozidriv hd. (2)	76 to * - DE40
2	2808	SCREW, No. 8-32 x 3/8 Pozidriv hd. (2)	76 to * - DE40
3	66036-72	CHARGER PLUG RECEPTACLE (for D. C. cable)	76 to * - DE40
4	66043-72	SPEED NUT, charger plug receptacle (4)	76 to * - DE40
5	66063-69B	D. C. CABLE AND PLUG (two prong)	76 to * - DE40
6	66070-72	SPRING CLIP, charger plug receptacle (2)	76 to * - DE40
7	66493-67	A. C. EXTENSION CORD	76 to * - DE40
8	66501-69	A. C. CABLE AND PLUG (three prong)	76 to * - DE40
9	66502-69	BUSHING, charger cable (2)	76 to * - DE40
10	66503-69	FUSE RECEPTACLE, with wires (2)	76 to * - DE40
11	66504-69	TIMER KNOB	76 to * - DE40
12	66505-69	HEAT SINK WITH DIODE	76 to * - DE40
13	66506-69	AMMETER	76 to * - DE40
14	66507-69	TIMER	76 to * - DE40
15	66508-69	FUSE, 30 Amp. (2)	76 to * - DE40
16	66509-69	CAPACITOR, 20.5 mfd.	76 to * - DE40
17	66512-69	TRANSFORMER	76 to * - DE40
18	66513-69	CASE, battery charger	76 to * - DE40
19	66514-69	CAPACITOR, 0.5 mfd.	76 to * - DE40

NOTE: Asterisk (*) indicates part is used for latest model year shown on cover.

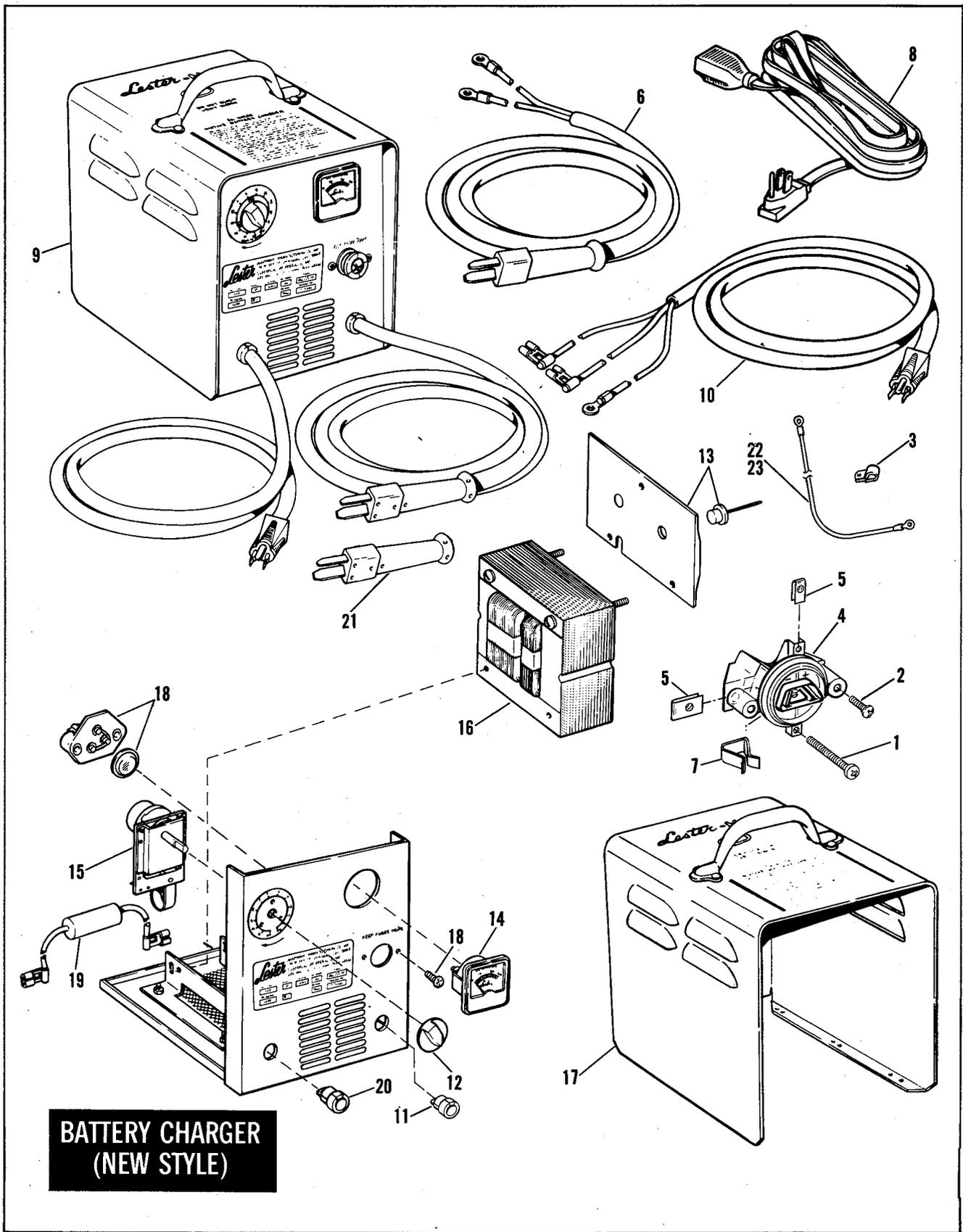

**BATTERY CHARGER
(NEW STYLE)**

BATTERY CHARGER (NEW STYLE)

INDEX PART		NAME	USED ON
NO.	NO.		
1	2807	SCREW, No. 8-32 x 1-1/2 Pozidriv hd. (2).....	76 to * - DE40
2	2808	SCREW, No. 8-32 x 3/8 Pozidriv hd. (2).....	76 to * - DE40
3	38712-68	CLAMP, diode to receptacle cable.....	76 to * - DE40
4	66036-72	CHARGER PLUG RECEPTACLE (for D. C. cable).....	76 to * - DE40
5	66043-72	SPEED NUT, charger plug receptacle (4).....	76 to * - DE40
6	66063-69B	D. C. CABLE AND PLUG (two prong).....	76 to * - DE40
7	66070-72	SPRING CLIP, charger plug receptacle.....	76 to * - DE40
8	66493-67	A. C. EXTENSION CORD.....	76 to * - DE40
9	66500-69A	BATTERY CHARGER, portable 36 V.....	76 to * - DE40
10	66501-76	A. C. CABLE AND PLUG (three prong).....	76 to * - DE40
11	66502-69	BUSHING, D. C. cable.....	76 to * - DE40
12	66504-69	TIMER KNOB.....	76 to * - DE40
13	66505-76	HEAT SINK WITH DIODE.....	76 to * - DE40
14	66506-69	AMMETER.....	76 to * - DE40
15	66507-69	TIMER.....	76 to * - DE40
16	66512-76	TRANSFORMER.....	76 to * - DE40
17	66513-76	CASE, battery charger.....	76 to * - DE40
18	66515-76	FUSE ASSEMBLY.....	76 to * - DE40
19	66516-76	CAPACITOR, 6 mfd.....	76 to * - DE40
20	66517-76	BUSHING, A. C. cable.....	76 to * - DE40
21	66518-76	PLUG, D. C. cable (replacement).....	76 to * - DE40
22	69626-75	WIRE, solenoid F to charger plug (red).....	76 to * - DE40
23	69627-75	WIRE, solenoid B to charger plug (black).....	76 to * - DE40

NOTE: Asterisk (*) indicates part is used for latest model year shown on cover.

WIRING

INDEX NO.	PART NO.	N A M E	USED ON
1	9857	WIRE TERMINAL, ring type - No. 10 hole - #16-22 wire ...	76 to * - DE40
2	9859	WIRE TERMINAL, ring type - 5/16 dia. hole - #16-22 wire.	76 to * - DE40
3	9866	WIRE TERMINAL, ring type - No. 10 hole - #10-12 wire ...	76 to * - DE40
4	9868	WIRE TERMINAL, ring type - 5/16 dia. hole - #10-12 wire.	76 to * - DE40
5	10006	CABLE STRAP	76 to * - DE40
6	41532-78	WIRE, solenoid B to snap switch	78 to * - DE40
7	69620-75	WIRING HARNESS, ignition switch	76 to * - DE40
8	69622-75	WIRE, solenoid B to buzzer	76 to * - DE40
9	69623-75	WIRE, solenoid F to solenoid R	76 to * - DE40
10	69624-75	WIRE, solenoids F & B to micro switch (2)	76 - DE40
11	69625-75	WIRE, solenoid B jumper	76 to * - DE40
12	69626-75	WIRE, solenoid F to charger plug (red)	76 to * - DE40
13	69627-75	WIRE, solenoid B to charger plug (black)	76 to * - DE40
14	69628-75	WIRE, resistor (4)	76 to * - DE40
15	70195-69A	CABLE, solenoid B to battery negative	76 to * - DE40
16	70199-63B	CONNECTOR CABLE, battery (5)	76 to * - DE40
17	70351-72	WIRE, motor A2 terminal	76 to * - DE40
18	70463-71A	CABLE, solenoid F to battery positive	76 to * - DE40
19	70465-67	WIRE, motor A1, S1 & S2 terminals	76 to * - DE40
20	70584-69	INSULATOR, flag terminal	76 to * - DE40
21	70589-69	INSULATOR, straight terminal	76 to * - DE40
22	71749-75	BRUSH CABLE ASSEMBLY	76 to * - DE40
23	71774-77	INSULATOR, straight terminal - snap switch wires (2)	77 to * - DE40
24	71775-77	WIRE, solenoid F to snap switch	77 to * - DE40
25	71776-77	WIRE, solenoid B to snap switch	77 - DE40

NOTE: Asterisk (*) indicates part is used for latest model year shown on cover.

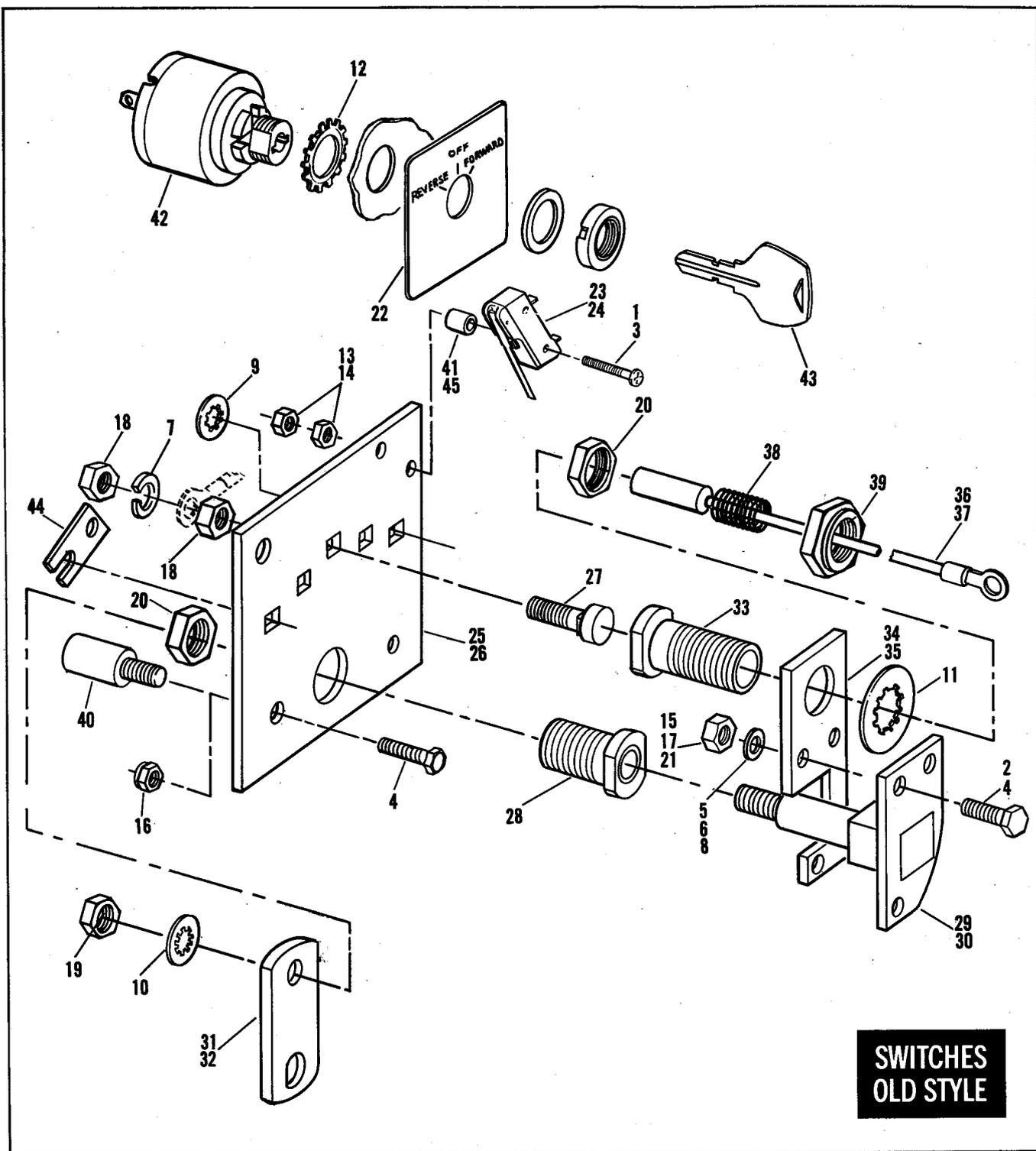

SWITCHES – OLD STYLE

INDEX PART
NO. NO.

N A M E

U S E D O N

NOTE: For greater service reliability, we recommend updating your vehicle with the improvement parts listed on the next page.

1	2338	SCREW, No. 4-48 x 2 Pozidriv pan hd. (2)	77 – DE40
2	2665	SCREW, No. 10-24 x 5/8 Pozidriv pan hd. (2)	76 – DE40
3	2727	SCREW, No. 6-32 x 1-3/4 Pozidriv pan hd. (2)	76 – DE40
4	3787	BOLT, 1/4-20 x 3/4 hex. hd. (2) (5 – 77)	76 & 77 – DE40
5	6703	WASHER, 1/4 x 5/8 x 1/16 (3)	77 – DE40
6	6716	WASHER, No. 10 x 1/2 x 3/64 (2)	Late 76 – DE40
7	7041	LOCKWASHER, 5/16 (4)	76 & 77 – DE40
8	7118	LOCKWASHER, No. 10 internal tooth (2)	Early 76 – DE40
9	7127	LOCKWASHER, 5/16 internal tooth	76 & 77 – DE40
10	7130W	LOCKWASHER, 3/8 internal tooth	76 & 77 – DE40
11	7142	LOCKWASHER, 3/4 internal tooth	76 & 77 – DE40
12	7242	LOCKWASHER, 5/8 external tooth	76 & 77 – DE40
13	7560	NUT, No. 4-48 x 3/32 x 1/4 hex. (4)	77 – DE40
14	7590	NUT, No. 6-32 x 1/8 x 5/16 hex. (4)	76 – DE40
15	7620W	LOCKNUT, No. 10-24 x 1/8 x 3/8 hex. (2)	Early 76 – DE40
16	7686	LOCKNUT, 1/4-20 x 5/16 x 7/16 hex. (2)	76 & 77 – DE40
17	7742	LOCKNUT, 1/4-20 x 7/32 x 7/16 hex. (3)	77 – DE40
18	7744	JAMNUT, 5/16-24 x 3/16 x 1/2 hex. (9) (6 – 77)	76 & 77 – DE40
19	7800W	LOCKNUT, 3/8-24 x 5/16 x 9/16 hex.	76 & 77 – DE40
20	7855W	LOCKNUT, 3/4-16 x 13/32 x 1-1/8 hex. (2)	76 & 77 – DE40
21	7998	LOCKNUT, No. 10-24 x 13/64 x 3/8 hex. (2)	Late 76 – DE40
22	71445-75	PLATE, ignition switch	76 & 77 – DE40
23	71506-63	SNAP SWITCH	76 – DE40
24	71506-77	SNAP SWITCH	77 – DE40
	71740-75	SPEED CONTROL SWITCH, complete	76 – DE40
	71740-77	SPEED CONTROL SWITCH, complete	77 – DE40
25	71741-75	BASE PLATE	76 – DE40
26	71741-77	BASE PLATE	77 – DE40
27	71742-75	CONTACT SCREW (5) (6 – 77))	76 & 77 – DE40
28	71743-75	BUSHING	76 & 77 – DE40
29	71744-75	PIVOT SHAFT	76 – DE40
30	71744-77	PIVOT SHAFT	77 – DE40
31	71746-75	CONTROL LEVER	76 – DE40
32	71746-77	CONTROL LEVER	77 – DE40
33	71747-75	BUSHING	76 & 77 – DE40
34	71748-75	PLATE, brush	76 – DE40
35	71748-77	PLATE, brush	77 – DE40
36	71749-75	BRUSH ASSEMBLY	76 & 77 – DE40
37	71750-75	BRUSH, with wire	76 & 77 – DE40
38	71752-75	SPRING	76 & 77 – DE40
39	71753-75	NUT, brush assembly	76 & 77 – DE40
40	71757-77	STUD, adaptor (adapts 71740-77 to 1976 cars)	76 – DE40
41	71761-75	SPACER; snap switch (2)	76 – DE40
42	71762-75	IGNITION SWITCH	76 & 77 – DE40
43	71765-75	KEY, ignition switch	76 & 77 – DE40
44	71772-77	CONNECTOR TAB, base plate contacts	77 – DE40
45	71773-77	SPACER, snap switch (2)	77 – DE40

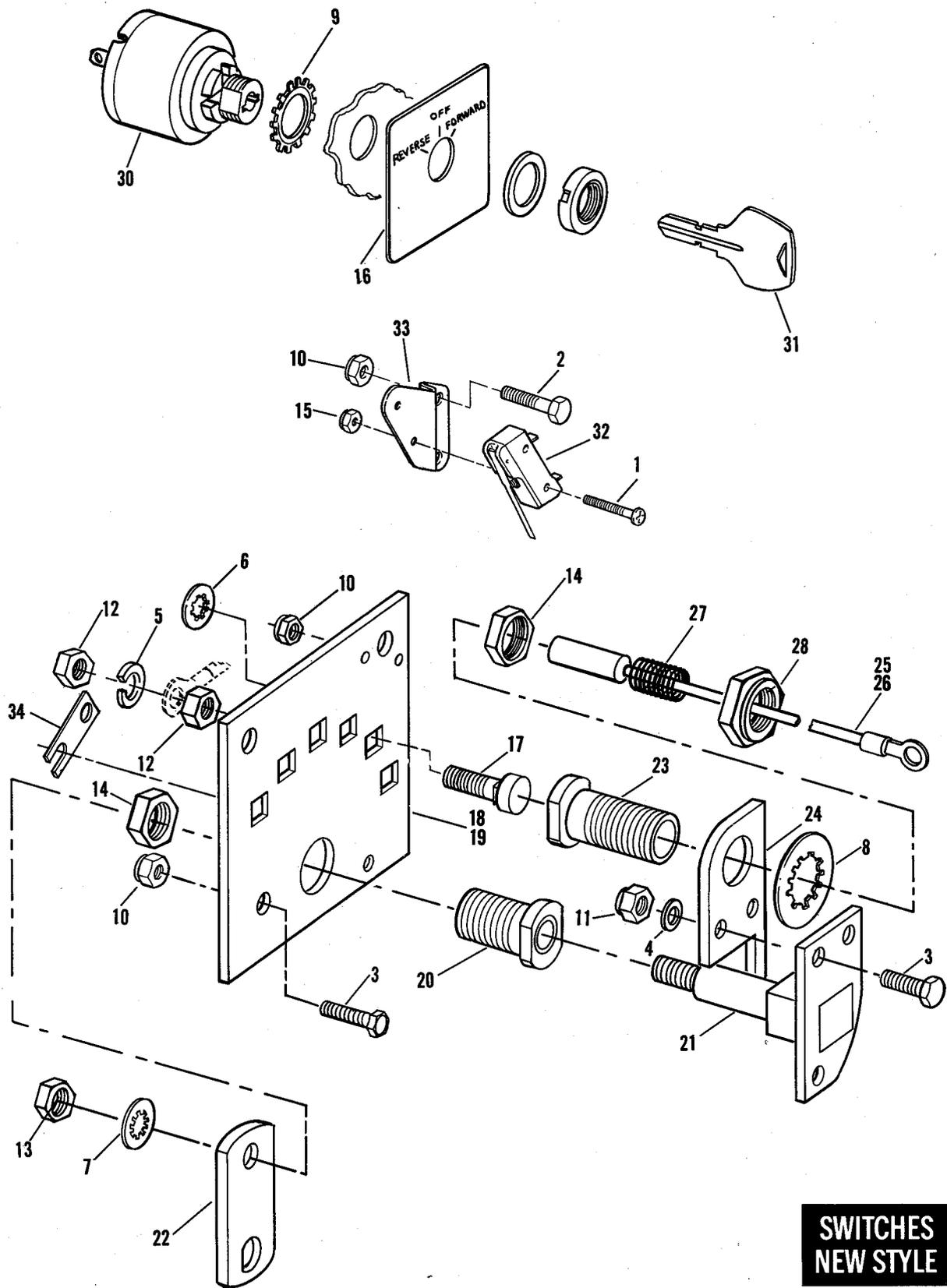

**SWITCHES
NEW STYLE**

SWITCHES – NEW STYLE

INDEX NO.	PART NO.	NAME	USED ON
-----------	----------	------	---------

NOTE: Improved Speed Switch Kit can only be installed on vehicles with improved Brake Kit already installed.

1	2556	SCREW, No. 6-32 x 1 Pozidriv pan hd. (2)	76 to * – DE40
2	3767B	BOLT, 1/4-20 x 5/8 hex. hd. (2)	76 to * – DE40
3	3787	BOLT, 1/4-20 x 3/4 hex. hd. (7)	76 to * – DE40
4	6703	WASHER, 1/4 x 5/8 x 1/16 (3)	76 to * – DE40
5	7041	LOCKWASHER, 5/16 (4)	76 to * – DE40
6	7127	LOCKWASHER, 5/16 internal tooth	76 to * – DE40
7	7130W	LOCKWASHER, 3/8 internal tooth	76 to * – DE40
8	7142	LOCKWASHER, 3/4 internal tooth	76 to * – DE40
9	7242	LOCKWASHER, 5/8 external tooth	76 to * – DE40
10	7686	LOCKNUT, 1/4-20 x 5/16 x 7/16 hex. (6)	76 to * – DE40
11	7742	LOCKNUT, 1/4-20 x 7/32 x 7/16 hex. (3)	76 to * – DE40
12	7744	JAMNUT, 5/16-24 x 3/16 x 1/2 hex. (10)	76 to * – DE40
13	7800W	LOCKNUT, 3/8-24 x 5/16 x 9/16 hex.	76 to * – DE40
14	7855W	LOCKNUT, 3/4-16 x 7/16 x 1-1/8 hex. (2)	76 to * – DE40
15	60031-61	LOCKNUT, No. 6-32 x 5/16 hex. (2)	76 to * – DE40
16	71445-75	PLATE, ignition switch	76 to * – DE40
17	71742-75	CONTACT SCREW (6)	76 to * – DE40
18	71700-77	CONTACT PLATE ASSEMBLY	77 to * – DE40
		Consists of:	
	6702	WASHER, connector tab screw, 5/16 x 11/16 x 1/16	
	7041	LOCKWASHER, connector tab screw, 5/16	
	7127	LOCKWASHER, base plate, 5/16 internal tooth	
	7744	JAMNUT, contact screw, 5/16-24 x 3/16 x 1/2 hex. (6)	
	71741-77	BASE PLATE	
	71742-75	CONTACT SCREW (6)	
	71772-77	CONNECTOR TAB, base plate contacts	
	71740-77A	SPEED CONTROL SWITCH, complete	76 to * – DE40
19	71741-77	BASE PLATE	76 to * – DE40
20	71743-75	BUSHING	76 to * – DE40
21	71744-77	PIVOT SHAFT	76 to * – DE40
22	71746-77	CONTROL LEVER	76 to * – DE40
23	71747-75	BUSHING	76 to * – DE40
24	71748-77	PLATE, brush	76 to * – DE40
25	71749-75	BRUSH ASSEMBLY	76 to * – DE40
26	71750-75	BRUSH, with wire	76 to * – DE40
27	71752-75	SPRING	76 to * – DE40
28	71753-75	NUT, brush assembly	76 to * – DE40
30	71762-75	IGNITION SWITCH	76 to * – DE40
31	71765-75	KEY, ignition switch	76 to * – DE40
32	71768-78	SNAP SWITCH	76 to * – DE40
33	71769-78	BRACKET, snap switch	76 to * – DE40
34	71772-77	CONNECTOR TAB, base plate contacts	76 to * – DE40

NOTE: For increased reliability, 1976 and 1977 models should be updated to 1978 vehicle specifications by installing the following Kit:

71710-78	SPEED SWITCH KIT	76 to * – DE40
	Consists of:	
	2556	SCREW, No. 6-32 x 1 Pozidriv pan hd. (2)
	3767B	SCREW, 1/4-20 x 5/8 hex. hd. (2)
	7686	LOCKNUT, 1/4-20 x 5/16 x 7/16 hex. (2)
	10006	CABLE STRAP
	41532-78	WIRE, solenoid B to snap switch
	60031-61	LOCKNUT, No. 6-32 x 5/16 hex. (2)
	71740-77A	SPEED CONTROL SWITCH, complete
	71768-78	SNAP SWITCH
	71769-78	BRACKET, snap switch
	71775-77	WIRE, solenoid F to snap switch

NOTE: Asterisk (*) indicates part is used for latest model year shown on cover.

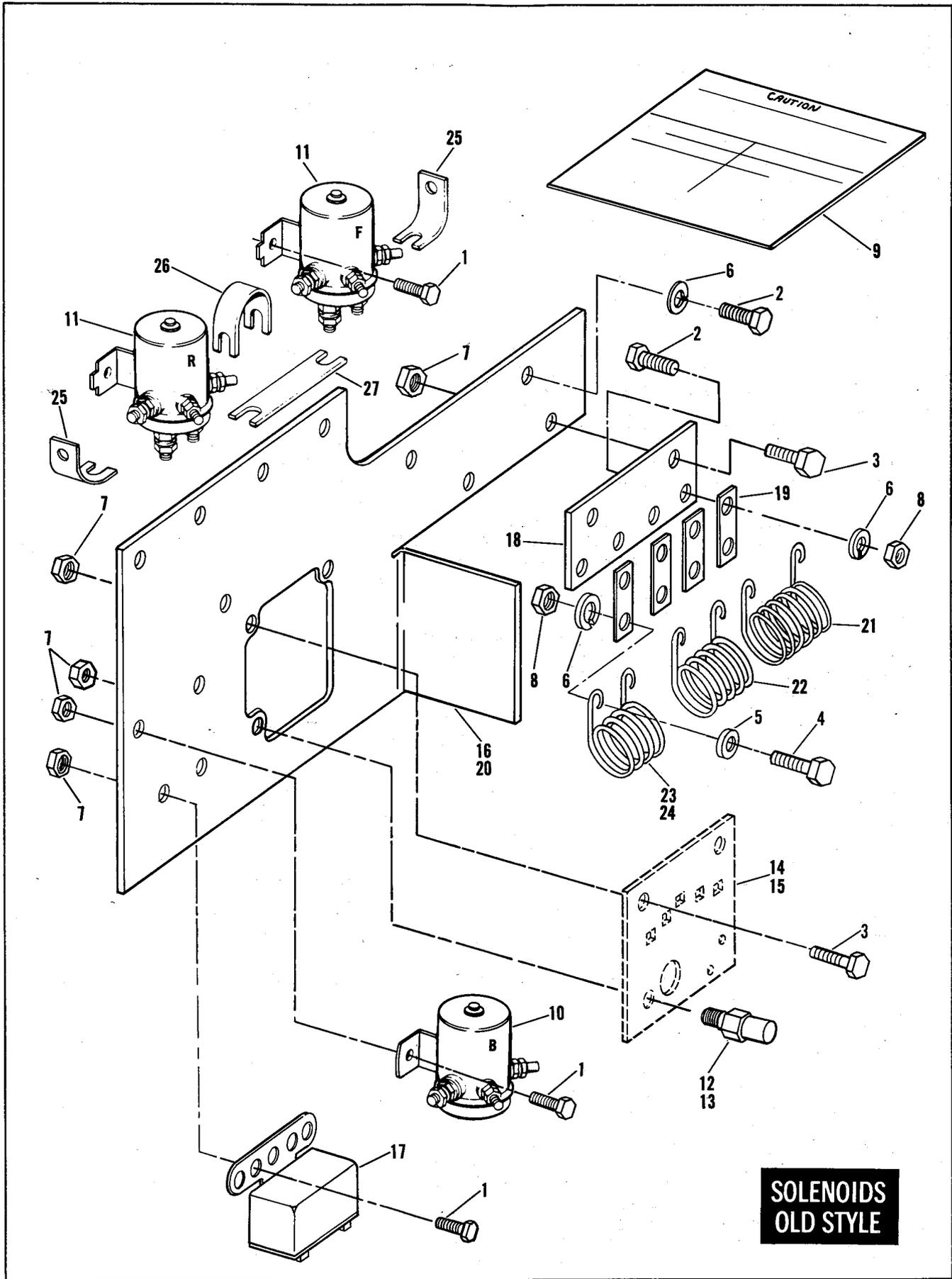

**SOLENOIDS
OLD STYLE**

SOLENOIDS – OLD STYLE

INDEX NO.	PART NO.	NAME	USED ON
-----------	----------	------	---------

NOTE: Old Style – 5 button speed switch panel, micro switch mounts to speed switch plate 71741-75 or 71741-77.

NOTE: For greater service reliability, we recommend updating your vehicle with the improvement parts listed on the next page.

1	3728	BOLT, 1/4-20 x 1/2 hex. hd. (8)	76 & 77 – DE40
2	3767B	BOLT, 1/4-20 x 5/8 hex. hd. (7)	76 & 77 – DE40
3	3787	BOLT, 1/4-20 x 3/4 hex. hd. (4)	76 & 77 – DE40
4	3802W	BOLT, 1/4-20 x 7/8 hex. hd. (4)	76 & 77 – DE40
5	6703	WASHER, 1/4 x 5/8 x 1/16 (4)	76 & 77 – DE40
6	7036	LOCKWASHER, 1/4 (11)	76 & 77 – DE40
7	7686	LOCKNUT, 1/4-20 x 5/16 x 7/16 hex. (13)	76 & 77 – DE40
8	7688	NUT, 1/4-20 x 7/32 x 7/16 hex. (8)	76 & 77 – DE40
9	47192-75	TRANSFER, check chart	76 & 77 – DE40
10	71470-63D	SOLENOID, 12 V. (four terminals)	76 & 77 – DE40
11	71476-66A	SOLENOID (six terminals) (2)	76 & 77 – DE40
12	71480-75	STUD, speed switch	76 – DE40
13	71480-77	STUD, speed switch	77 – DE40
14	71740-75	SPEED CONTROL SWITCH, complete (see index)	76 – DE40
15	71740-77	SPEED CONTROL SWITCH, complete (see index)	77 – DE40
16	71754-77A	PLATE, solenoid mounting	77 – DE40
17	71756-75	BUZZER	76 & 77 – DE40
18	71758-75	PLATE, resistor mounting	76 & 77 – DE40
19	71759-75	PLATE, resistor coils (4)	76 & 77 – DE40
20	71763-75	PLATE, solenoid mounting	76 – DE40
21	74601-75	RESISTOR COIL, first speed	76 & 77 – DE40
22	74602-75	RESISTOR COIL, second speed	76 & 77 – DE40
23	74603-75	RESISTOR COIL, third speed	76 – DE40
24	74603-77	RESISTOR COIL, third speed	77 – DE40
25	74893-67	CONNECTOR BAR, right angle (2)	76 & 77 – DE40
26	74894-63A	CONNECTOR BAR, curved	76 & 77 – DE40
27	74895-63	CONNECTOR BAR, straight	76 & 77 – DE40

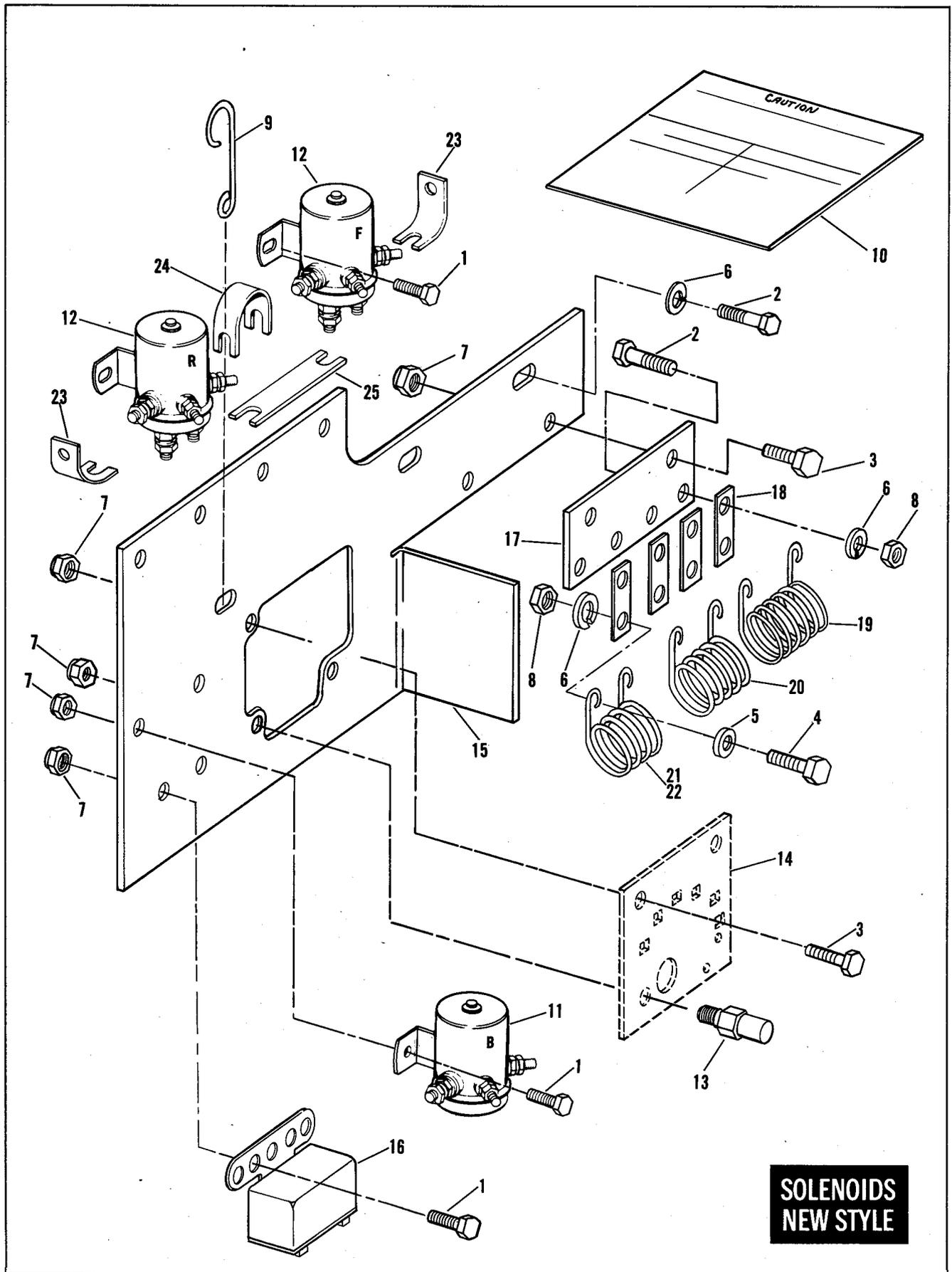

**SOLENOIDS
NEW STYLE**

SOLENOIDS – NEW STYLE

INDEX NO.	PART NO.	NAME	USED ON
-----------	----------	------	---------

NOTE: New Style – 6 button speed switch panel, micro switch mounts to base plate 71754–77A.

1	3728	BOLT, 1/4-20 x 1/2 hex. hd. (7)	76 to * – DE40
2	3767B	BOLT, 1/4-20 x 5/8 hex. hd. (7)	76 to * – DE40
3	3787	BOLT, 1/4-20 x 3/4 hex. hd. (6)	76 to * – DE40
4	3802W	BOLT, 1/4-20 x 7/8 hex. hd. (4)	76 to * – DE40
5	6703	WASHER, 1/4 x 5/8 x 1/16 (4)	76 to * – DE40
6	7036	LOCKWASHER, 1/4 (11)	76 to * – DE40
7	7686	LOCKNUT, 1/4-20 x 5/16 x 7/16 hex. (15)	76 to * – DE40
8	7688	NUT, 1/4-20 x 7/32 x 7/16 hex. (8)	76 to * – DE40
9	42629–78	CABLE GUIDE	76 to * – DE40
10	47192–75	TRANSFER (check chart)	76 to * – DE40
11	71470–63D	SOLENOID, 12 V. (four terminals)	76 to * – DE40
12	71476–66B	SOLENOID (six terminals) (2)	76 to * – DE40
13	71480–77	STUD, speed switch mounting	76 to * – DE40
14	71740–77A	SPEED CONTROL SWITCH, complete (see index)	76 to * – DE40
15	71754–77A	PLATE, solenoid mounting	76 to * – DE40
16	71756–75	BUZZER	76 to * – DE40
17	71758–75	PLATE, resistor mounting	76 to * – DE40
18	71759–75	PLATE, resistor coils (4)	76 to * – DE40
19	74601–75	RESISTOR COIL, first speed	76 to * – DE40
20	74602–75	RESISTOR COIL, second speed	76 to * – DE40
21	74603–75	RESISTOR COIL, third speed	76 – DE40
22	74603–77	RESISTOR COIL, third speed	77 to * – DE40
23	74893–67	CONNECTOR BAR, right angle (2)	76 to * – DE40
24	74894–63A	CONNECTOR BAR, curved	76 to * – DE40
25	74895–63	CONNECTOR BAR, straight	76 to * – DE40

NOTE: Asterisk (*) indicates part is used for latest model year shown on cover.

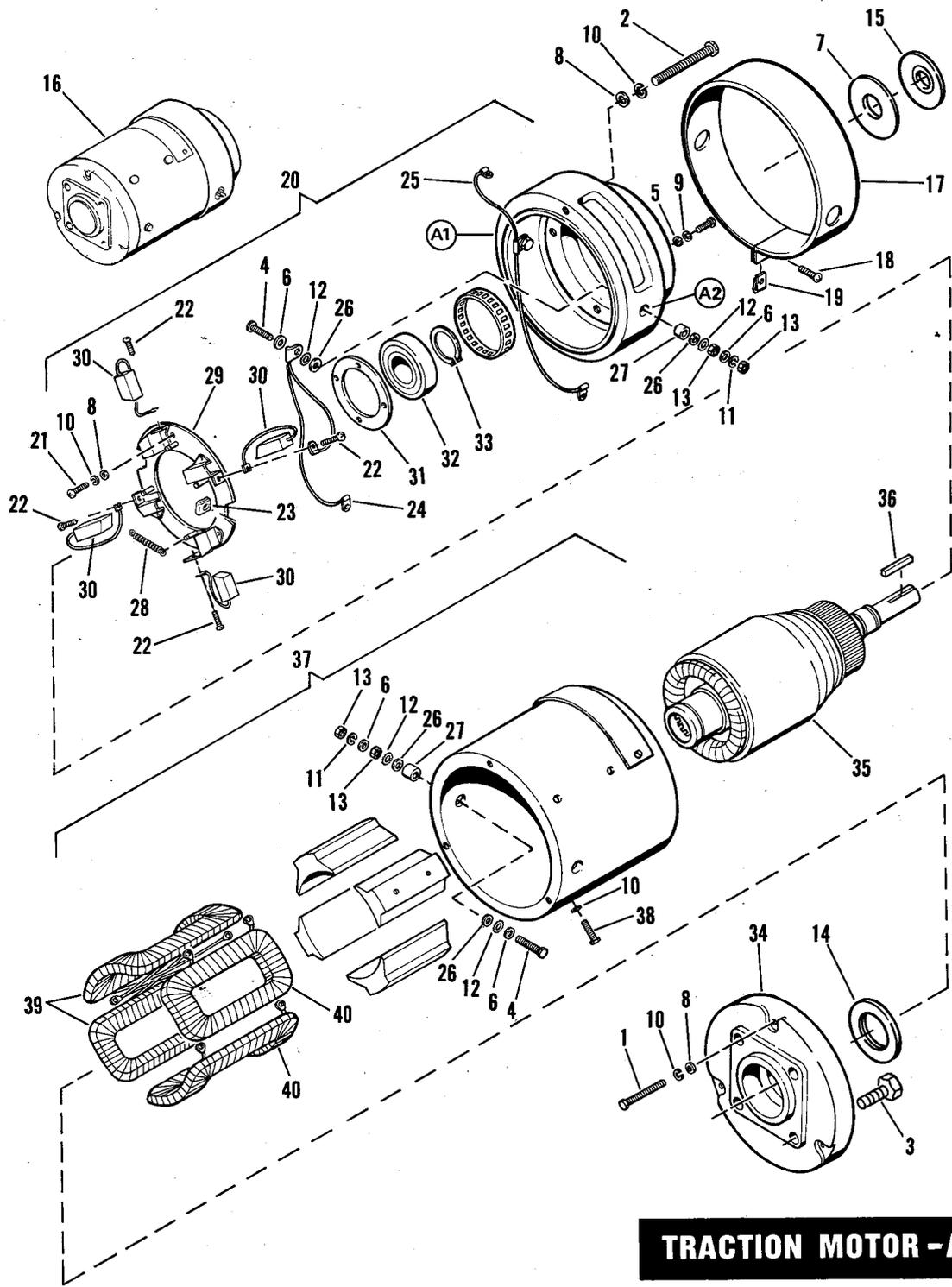

TRACTION MOTOR - AMF

TRACTION MOTOR - AMF

INDEX PART		NAME	USED ON
NO.	NO.		
1	2551W	BOLT, 1/4-20 x 1 hex. hd. (3)	76 to * - DE40
2	3768	BOLT, 1/4-20 x 2-1/2 hex. hd. (2)	76 to * - DE40
3	4085B	BOLT, 3/8-16 x 7/8 hex. hd. (4)	76 to * - DE40
4	4730	BOLT, 5/16-24 x 1-3/4 hex. hd. (4)	76 to * - DE40
5	6192	WASHER, No. 8 x 7/16 x 3/64 (4)	76 to * - DE40
6	6333	WASHER, 5/16 x 7/8 x 5/64 (8)	76 to * - DE40
7	6681	NYLON WASHER, 27/32 x 2-3/8 x 1/32	76 to * - DE40
8	6703	WASHER, 1/4 x 5/8 x 1/16 (9)	76 to * - DE40
9	7015	LOCKWASHER, No. 8 (4)	76 to * - DE40
10	7036	LOCKWASHER, 1/4 (17)	76 to * - DE40
11	7041	LOCKWASHER, 5/16 (4)	76 to * - DE40
12	7145W	LOCKWASHER, 3/8 external tooth (8)	76 to * - DE40
13	7753	NUT, 5/16-24 x 1/4 x 1/2 hex. hd. (8)	76 to * - DE40
14	12041	OIL SEAL, motor shaft	76 to * - DE40
15	47749-67A	SEAL, motor shaft	76 to * - DE40
16	83170-75	TRACTION MOTOR (AMF)	76 to * - DE40
17	83171-75	BRUSH COVER	76 to * - DE40
18	83172-75	SCREW, brush cover, No. 8-32 x 1/2	76 to * - DE40
19	83173-75	SPEED NUT, brush cover	76 to * - DE40
20	83174-75	FRAME ASSEMBLY, commutator end	76 to * - DE40
21	83175-75	SCREW, brush holder, 1/4-20 x 1/2 (4)	76 to * - DE40
22	83176-75	SCREW, brush terminal, No. 10 self tapping (4)	76 to * - DE40
23	83177-75	SPEED NUT, brush terminal screw (4)	76 to * - DE40
24	83178-75	WIRING HARNESS, terminal A2	76 to * - DE40
25	83179-75	WIRE, terminal A1	76 to * - DE40
26	83180-75	WASHER, terminals (8)	76 to * - DE40
27	83181-75	BUSHING, terminals (4)	76 to * - DE40
28	83182-75	SPRING (4)	76 to * - DE40
29	83183-75	BRUSH HOLDER	76 to * - DE40
30	83184-75	BRUSH (4)	76 to * - DE40
31	83185-75	PLATE, bearing	76 to * - DE40
32	83186-75	BALL BEARING	76 to * - DE40
33	83187-75	RETAINING RING	76 to * - DE40
34	83188-75	END COVER	76 to * - DE40
35	83189-75	ARMATURE	76 to * - DE40
36	83190-75	STRAIGHT KEY	76 to * - DE40
37	83191-75	FRAME ASSEMBLY, with coils and shoes	76 to * - DE40
38	83192-75	BOLT, pole shoes, 1/4-20 x 7/8 hex. hd. (8)	76 to * - DE40
39	83193-75	COIL ASSEMBLY	76 to * - DE40
40	83194-75	COIL (2)	76 to * - DE40

NOTE: Asterisk (*) indicates part is used for latest model year shown on cover.

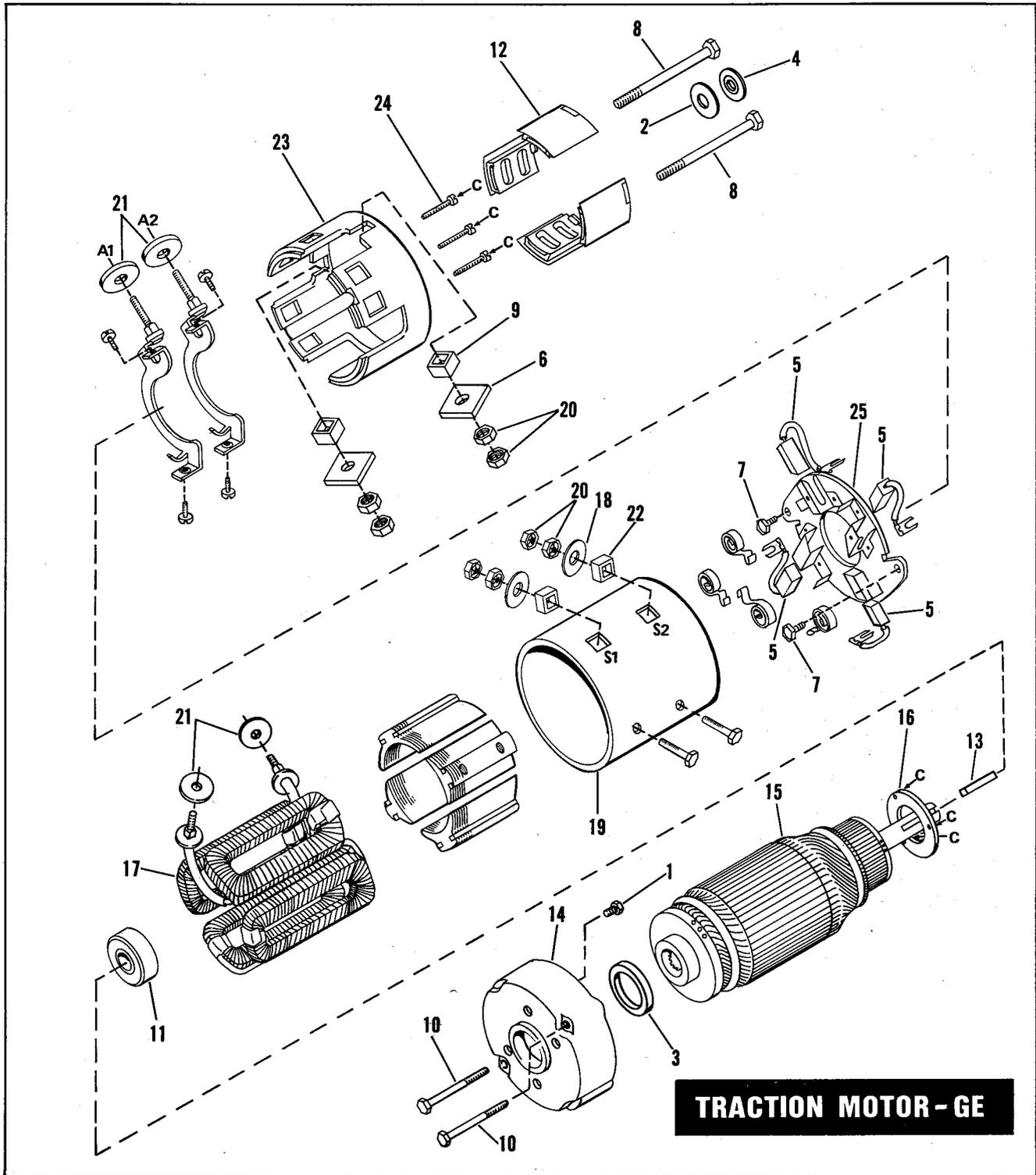

TRACTION MOTOR - GE

INDEX NO.	PART NO.	N A M E	USED ON
1	4085B	BOLT, 3/8-16 x 7/8 hex. hd. (4)	76 to * - DE40
2	6681	NYLON WASHER, 27/32 x 2-3/8 x 1/32	76 to * - DE40
3	12041	OIL SEAL	76; 78 to * - DE40
4	47749-67A	SEAL, motor shaft	76 to * - DE40
5	70491-73	SET OF 4 BRUSHES WITH WIRES	76 to * - DE40
6	72342-73	SQUARE WASHER, terminal studs (2)	76 to * - DE40
7	72343-73	SCREW, brush plate (2)	76 to * - DE40
8	72347-73	BOLT, commutator end cover (2)	76 to * - DE40
9	72352-73	SQUARE INSULATOR, terminals A1 & A2 (2)	76 to * - DE40
10	72379-73	BOLT, end cover (2)	76 to * - DE40
11	72380-72	BALL BEARING	76 to * - DE40
12	72386-73	BRUSH COVER (4)	76 to * - DE40
13	83190-75	STRAIGHT KEY	76 to * - DE40
	83250-75	TRACTION MOTOR (GE)	76 to * - DE40
14	83252-75	END COVER	76 to * - DE40
15	83253-75	ARMATURE	76 to * - DE40
16	83254-75	RETAINING RING, bearing	76 to * - DE40
17	83255-75	FIELD COIL SET	76 to * - DE40
18	83256-75	WASHER, terminals (2)	76 to * - DE40
19	83257-75	FRAME ASSEMBLY, with coils and shoes	76 to * - DE40
20	83259-75	NUT, terminals (8)	76 to * - DE40
21	83260-75	WASHER, terminals (4)	76 to * - DE40
22	83262-75	SQUARE INSULATOR, terminals S1 & S2 (2)	76 to * - DE40
23	83263-75	END COVER, commutator end	76 to * - DE40
24	83264-75	SCREW, bearing retainer (3)	76 to * - DE40
25	83268-75	BRUSH PLATE, with springs, brushes and A1 & A2 terminal stud assemblies	76 to * - DE40

NOTE: Asterisk (*) indicates part is used for latest model year shown on cover.

REAR AXLE AND DIFFERENTIAL - DANA

INDEX NO.	PART NO.	NAME	USED ON
1	559	COTTER PIN, 1/8 dia. x 1-1/4 (2).....	76 to * - DE40
	82805-75	REAR AXLE ASSEMBLY, complete.....	76 to * - DE40
2	82823-67	BREATHER VALVE, axle housing.....	76 to * - DE40
3	82844-63A	ROLLER BEARING, differential (2).....	76 to * - DE40
4	82948-74	MATCHED PINION AND GEAR.....	76 to * - DE40
5	82953-74	CUP, pinion nut.....	76 to * - DE40
6	83032-73	SHIM, pinion bearing - front - .003" (2).....	76 to * - DE40
	83033-73	SHIM, pinion bearing - front - .005" (2).....	76 to * - DE40
	83034-73	SHIM, pinion bearing - front - .010" (2).....	76 to * - DE40
	83035-73	SHIM, pinion bearing - front - .030".....	76 to * - DE40
7	83039-73	DRAIN PLUG.....	76 to * - DE40
8	83041-73	PLUG, axle housing cover.....	76 to * - DE40
9	83042-73	COVER, axle housing.....	76 to * - DE40
10	83043-73	GASKET, axle end bearing retainer (4).....	76 to * - DE40
11	83053-63A	SPACER, pinion bearings.....	76 to * - DE40
12	83072-73	SHIM, pinion bearing - rear - .003".....	76 to * - DE40
	83073-73	SHIM, pinion bearing - rear - .005".....	76 to * - DE40
	83074-73	SHIM, pinion bearing - rear - .010".....	76 to * - DE40
13	83085-73	STUD, wheel hub (8).....	76 to * - DE40
14	83087-73	FELT SEAL, wheel hub (2).....	76 to * - DE40
15	83096-63A	SHIM, differential bearing - .003".....	76 to * - DE40
	83097-63A	SHIM, differential bearing - .005".....	76 to * - DE40
	83098-63A	SHIM, differential bearing - .010".....	76 to * - DE40
	83099-63A	SHIM, differential bearing - .030".....	76 to * - DE40
16	83100-73	ROLLER BEARING, wheel hub (2).....	76 to * - DE40
17	83103-73	LOCK PIN, pinion mate shaft.....	76 to * - DE40
18	83104-73	SHAFT, pinion mate.....	76 to * - DE40
19	83106-63A	BOLT, drive gear (10).....	76 to * - DE40
20	83108-74	NUT, pinion.....	76 to * - DE40
21	83112-63A	ROLLER BEARING, pinion (2).....	76 to * - DE40
22	83113-73	GASKET, axle housing cover.....	76 to * - DE40
23	83115-73	BOLT, axle housing cover (9).....	76 to * - DE40
24	83119-73	BOLT, wheel hub bearing retainer (8).....	76 to * - DE40
25	83125-73	DIFFERENTIAL CASE ASSEMBLY.....	76 to * - DE40
26	83126-73	DUST SHIELD, wheel hub bearing (2).....	76 to * - DE40
27	83131-63	NUT, axle shaft (2).....	76 to * - DE40
28	83134-63A	OIL SLINGER, pinion.....	76 to * - DE40
29	83140-75	AXLE SHAFT, right.....	76 to * - DE40
30	83141-75	AXLE SHAFT, left.....	76 to * - DE40
31	83142-75	HUB, rear wheel (2).....	76 to * - DE40
32	83143-75	AXLE SLEEVE, wheel hub roller bearing (2).....	76 to * - DE40
33	83163-63A	OIL SEAL, axle tube (2).....	76 to * - DE40
34	83165-73	RETAINER, wheel hub bearing (2).....	76 to * - DE40

NOTE: Asterisk (*) indicates part is used for latest model year shown on cover.

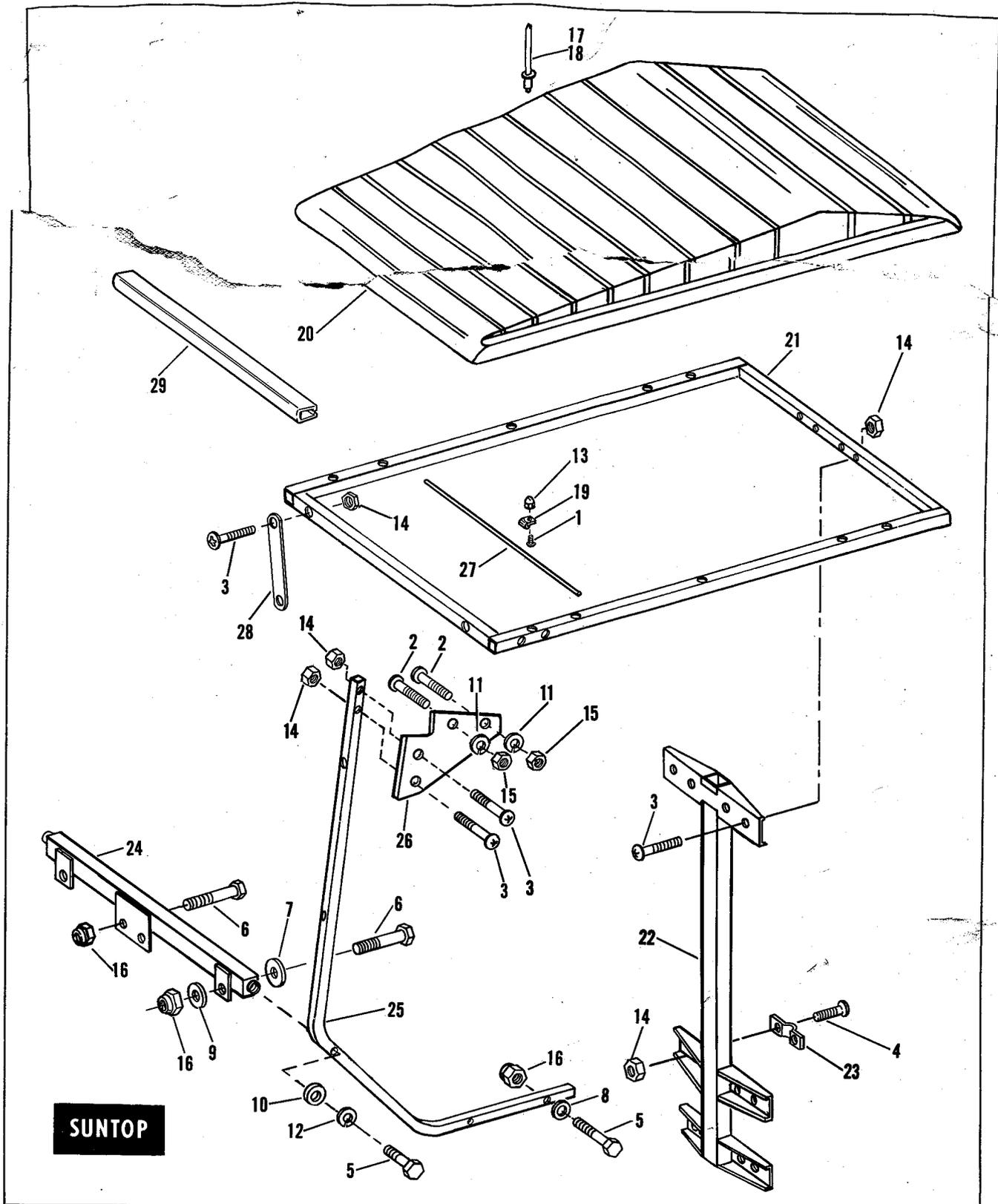

SUNTOP

INDEX NO.	PART NO.	N A M E	U S E D O N
1	2583	SCREW, No. 10-32 x 3/8 Pozidriv pan hd.	76 to * - DE40
2	2602	SCREW, 1/4-20 x 1-1/4 Pozidriv pan hd. (4).....	76 to * - DE40
3	2603	SCREW, 1/4-20 x 1-1/2 Pozidriv pan hd. (12).....	76 to * - DE40
4	2774	SCREW, 1/4-20 x 5/8 Pozidriv pan hd. (8).....	76 to * - DE40
5	2887W	BOLT, 5/16-18 x 1-3/4 hex. hd. (6).....	76 to * - DE40
6	4017	BOLT, 5/16-18 x 1 hex. hd. (4).....	76 to * - DE40
7	5927	WASHER, 5/16 x 1-1/2 x 3/32 rubber (2).....	76 to * - DE40
8	6332B	WASHER, 5/16 x 15/16 x 1/16 (4).....	76 to * - DE40
9	6678W	WASHER, 11/32 x 1-1/2 x 5/32 (2).....	76 to * - DE40
10	6702	WASHER, 5/16 x 11/16 x 1/16 (2).....	76 to * - DE40
11	7036	LOCKWASHER, 1/4 (4).....	76 to * - DE40
12	7041	LOCKWASHER, 5/16 (2).....	76 to * - DE40
13	7602	ACORN NUT, No. 10-32 (nylon).....	76 to * - DE40
14	7686	LOCKNUT, 1/4-20 x 5/16 x 7/16 hex. (20).....	76 to * - DE40
15	7688	NUT, 1/4-20 x 7/32 x 7/16 hex. (4).....	76 to * - DE40
16	7710W	LOCKNUT, 5/16-18 x 1/4 x 1/2 hex. (8).....	76 to * - DE40
17	8488B	POP RIVET, 3/16 x 3/8 x 5/8 dia. hd. (black) (10).....	Late 76 to * - DE40
18	8687	POP RIVET, 3/16 x 3/8 x 3/8 dia. hd. (10).....	Early 76 - DE40
19	71795-63A	CLIP, support rod.....	76 to * - DE40
	89500-75	SUNTOP, complete.....	76 to * - DE40
20	89501-75	SUNTOP WITH FRAME.....	76 to * - DE40
21	89503-75	SUPPORT FRAME, suntop.....	76 to * - DE40
22	89508-75	SUPPORT TUBE, rear.....	76 to * - DE40
23	89510-75	CLAMP (4).....	76 to * - DE40
24	89511-75	SUPPORT TUBE, crossover.....	76 to * - DE40
25	89514-75	SUPPORT TUBE, front (2).....	76 to * - DE40
26	89515-75	REINFORCEMENT PLATE, front (2).....	76 to * - DE40
27	89516-75	SUPPORT ROD, suntop.....	76 to * - DE40
28	89517-76	BRACE (2).....	76 to * - DE40
29	89520-77	TRIM, suntop edge.....	76 to * - DE40

NOTE: Asterisk (*) indicates part is used for latest model year shown on cover.

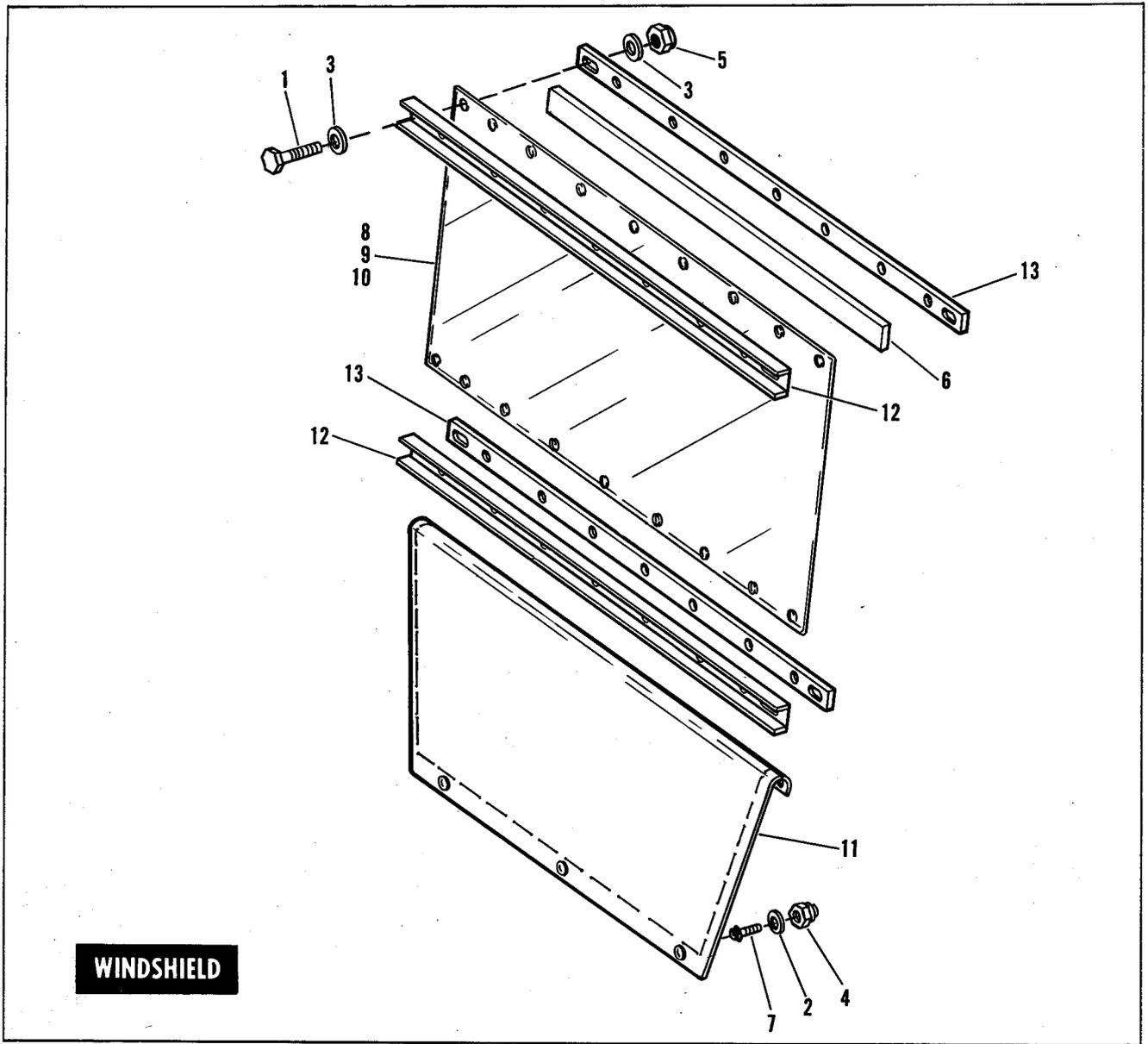

WINDSHIELD

WINDSHIELD

INDEX NO.	PART NO.	N A M E	USED ON
1	3454	BOLT, 1/4-20 x 1-3/4 hex. hd. (4).....	76 to * - DE40
2	6192	WASHER, No. 8 x 7/16 x 3/64 (3).....	76 to * - DE40
3	6703	WASHER, 1/4 x 5/8 x 1/1 (8).....	76 to * - DE40
4	7631W	LOCKNUT, No. 8-32 x 1/4 x 3/8 hex. (3).....	76 to * - DE40
5	7686	LOCKNUT, 1/4-20 x 5/16 x 7/16 hex. (4).....	76 to * - DE40
6	58106-76	PAD, windshield (suntop support tubes) (2).....	76 to * - DE40
7	58131-66	STUD (3).....	76 to * - DE40
8	58310-76	WINDSHIELD KIT.....	76 to * - DE40
9	58311-76	WINDSHIELD ASSEMBLY.....	76 to * - DE40
10	58312-76	WINDSHIELD, only.....	76 to * - DE40
11	58313-76	CURTAIN.....	76 to * - DE40
12	58314-76	CHANNEL (2).....	76 to * - DE40
13	58315-76	STRIP, channel (2).....	76 to * - DE40

NOTE: Asterisk (*) indicates part is used for latest model year shown on cover.

COMMON HARDWARE

COTTER PINS

515	COTTER PIN, 1/16 dia. x 1/2 lg.
520W	COTTER PIN, 1/8 dia. x 1 lg.
534	COTTER PIN, 1/16 dia. x 1 lg.
559	COTTER PIN, 1/8 dia. x 1-1/4 lg.
576	COTTER PIN, 1/8 dia. x 1-3/4 lg.

SCREWS

2004	SCREW, 3/8-16 x 2 pan hd.
2338	SCREW, No. 4-48 x 2 Pozidriv pan hd.
2500	SCREW, 1/4-20 x 1 Pozidriv truss hd.
2556	SCREW, No. 6-32 x 1 Pozidriv pan hd.
2560	SCREW, No. 10-24 x 1-1/4 self tapping Pozidriv pan hd.
2577	SCREW, 1/4-20 x 7/8 Pozidriv pan hd.
2583	SCREW, No. 10-32 x 3/8 Pozidriv pan hd.
2602	SCREW, 1/4-20 x 1-1/4 Pozidriv pan hd.
2603	SCREW, 1/4-20 x 1-1/2 Pozidriv pan hd.
2605	SCREW, 5/16-18 x 1-3/4 Pozidriv pan hd.
2659	SCREW, No. 10-24 x 7/8 Pozidriv pan hd.
2665	SCREW, No. 10-24 x 5/8 Pozidriv pan hd.
2685W	SCREW, No. 10-24 x 5/8 self tapping hex. hd.
2727	SCREW, No. 6-32 x 1-3/4 Pozidriv pan hd.
2745	SCREW, 1/4-20 x 3/4 self tapping truss hd.
2774	SCREW, 1/4-20 x 5/8 Pozidriv pan hd.
2778	SCREW, No. 10-16 x 1-1/2 self tapping hex. washer hd.
2807	SCREW, No. 8-32 x 1-1/2 Pozidriv pan hd.
2808	SCREW, No. 8-32 x 3/8 Pozidriv pan hd.

BOLTS

2551W	BOLT, 1/4-20 x 1 hex. hd.
2818	BOLT, 5/16-18 x 1-1/2 hex. hd.
2821	BOLT, 1/4-20 x 2-1/4 hex. hd.
2870W	BOLT, 7/16-14 x 3 hex. hd.
2887W	BOLT, 5/16-18 x 1-3/4 hex. hd.
3449	BOLT, 5/16-24 x 2-1/4 hex. hd.
3454	BOLT, 1/4-20 x 1-3/4 hex. hd.
3455	BOLT, 3/8-24 x 3-3/4 hex. hd.
3456	BOLT, 3/8-24 x 7 hex. hd.
3459	BOLT, 5/16-18 x 1-1/2 hex. washer hd.
3650	BOLT, 1/4-20 x 3 hex. hd.
3728	BOLT, 1/4-20 x 1/2 hex. hd.
3767B	BOLT, 1/4-20 x 5/8 hex. hd.
3768	BOLT, 1/4-20 x 2-1/2 hex. hd.
3783	BOLT, 1/4-20 x 1-3/4 hex. washer hd.
3787	BOLT, 1/4-20 x 3/4 hex. hd.
3802W	BOLT, 1/4-20 x 7/8 hex. hd.
3854	BOLT, 7/16-14 x 1 hex. hd.
3858	BOLT, 7/16-14 x 7/8 hex. hd.
3953W	BOLT, 5/16-24 x 1/2 hex. hd.
3960W	BOLT, 5/16-24 x 1 hex. hd.
3974HW	BOLT, 5/16-24 x 3/4 hex. hd.
3978	BOLT, 5/16-18 x 3/4 hex. hd.
3987	BOLT, 5/16-18 x 3/4 hex. hd.
3991	BOLT, 5/16-18 x 7/8 hex. hd.
3996	BOLT, 5/16-24 x 7/8 hex. hd.
4014W	BOLT, 5/16-24 x 1-1/4 hex. hd.
4017	BOLT, 5/16-18 x 1 hex. hd.
4064W	BOLT, 5/16-24 x 3-3/4 hex. hd. (drilled)
4085B	BOLT, 3/8-16 x 7/8 hex. hd.
4253	BOLT, 7/16-20 x 3-1/2 hex. hd.
4725	BOLT, 5/16-24 x 2-3/4 hex. hd.
4730	BOLT, 5/16-24 x 1-3/4 hex. hd.

WASHERS

6150W	WASHER, 3/16 x 3/8 x 1/16
6192	WASHER, No. 8 x 7/16 x 3/64
6220W	WASHER, 1/4 x 7/16 x 1/32

WASHERS (CONT'D.)

6228W	WASHER, 1/4 x 1/2 x 1/16
6253W	WASHER, 1/4 x 3/4 x 1/16
6310B	WASHER, 5/16 x 9/16 x 1/32
6332B	WASHER, 5/16 x 15/16 x 1/16
6333	WASHER, 5/16 x 7/8 x 5/64
6334	WASHER, 7/16 x 15/16 x 1/16
6336B	WASHER, 5/16 x 15/16 x 5/32
6346	WASHER, 1/2 x 1-3/8 x 1/32 Delrin
6347	WASHER, 5/8 x 1-1/4 x 1/8 (bronze)
6375B	WASHER, 3/8 x 9/16 x 1/32
6417W	WASHER, 3/8 x 1-1/8 x 1/8
6653	WASHER, 5/8 x 1-5/16 x 3/32
6678W	WASHER, 11/32 x 1-1/2 x 5/32
6698	WASHER, 5/8 x 1-7/16 x 1/16 (bronze)
6701	WASHER, 3/8 x 13/16 x 1/16
6702	WASHER, 5/16 x 11/16 x 1/16
6703	WASHER, 1/4 x 5/8 x 1/16
6716	WASHER, No. 10 x 1/2 x 3/64

LOCKWASHERS

7015	LOCKWASHER, No. 8
7022	LOCKWASHER, 5/8
7036	LOCKWASHER, 1/4
7039	LOCKWASHER, 7/16
7041	LOCKWASHER, 5/16
7068	LOCKWASHER, 1/2
7069	LOCKWASHER, No. 10
7118	LOCKWASHER, No. 10 internal tooth
7127	LOCKWASHER, 5/16 internal tooth
7130W	LOCKWASHER, 3/8 internal tooth
7142	LOCKWASHER, 3/4 internal tooth
7145W	LOCKWASHER, 3/8 external tooth
7242	LOCKWASHER, 5/8 external tooth

NUTS

7506	LOCKNUT, 3/8-24 x 3/8 x 9/16 hex.
7512	LOCKNUT, 3/8-16 x 9/16 hex. washer
7560	NUT, No. 4-48 x 3/32 x 1/4 hex.
7590	NUT, No. 6-32 x 1/8 x 5/16 hex.
7620W	NUT, No. 10-24 x 1/8 x 3/8 hex.
7631W	LOCKNUT, No. 8-32 x 1/4 x 3/8 hex.
7644	JAMNUT, 1/2-20 x 5/16 x 3/4 hex.
7686	LOCKNUT, 1/4-20 x 5/16 x 7/16 hex.
7688	NUT, 1/4-20 x 7/32 x 7/16 hex.
7710W	LOCKNUT, 5/16-18 x 1/4 x 1/2 hex.
7725	LOCKNUT, 5/16-24 x 11/32 x 1/2 hex.
7727	LOCKNUT, 5/16-24 x 1/4 x 1/2 hex.
7728	CASTLE NUT, 5/16-24 x 5/16 x 1/2 hex.
7729	LOCKNUT, 5/16-24 x 1/4 x 1/2 hex.
7739	LOCKNUT, 5/16-18 x 11/32 x 1/2 hex.
7740	LOCKNUT, 5/16-18 x 1/4 x 1/2 hex.
7741	LOCKNUT, 1/2-20 x 1/2 x 3/4 hex.
7742	LOCKNUT, 1/4-20 x 7/32 x 7/16 hex.
7744	JAMNUT, 5/16-24 x 3/16 x 1/2 hex.
7748W	NUT, 5/16-18 x 1/4 x 1/2 hex.
7753	NUT, 5/16-24 x 1/4 x 1/2 hex.
7763W	JAMNUT, 5/16-18 x 3/16 x 1/2 hex.
7775	LOCKNUT, 3/8-24 x 7/16 x 9/16 hex.
7800W	NUT, 3/8-24 x 5/16 x 9/16 hex.
7812W	LOCKNUT, 1/2-20 x 5/16 x 3/4 hex.
7825	LOCKNUT, 7/16-20 x 7/16 x 5/8 hex.
7827W	LOCKNUT, 7/16-14 x 7/16 x 5/8 hex.
7845	NUT, 1/2-20 x 7/16 x 3/4 hex.
7874	CASTLE NUT, 1-12 x 7/8 x 1-1/2 hex.
7855W	LOCKNUT, 3/4-16 x 13/32 x 1-1/8 hex.
7990	LOCKNUT, 5/8-18 x 3/8 x 15/16 hex.
7995	LOCKNUT, 5/8-18 x 3/8 x 15/16 hex.
7998	LOCKNUT, No. 10-24 x 13/64 x 3/8 hex.

NUMERICAL INDEX

Part No.	Page	Part No.	Page	Part No.	Page	Part No.	Page	Part No.	Page
384	7	2821	31	3991	25		31	7068	25
515	3	2870-	W 25	3996	17		31	7069	3
	5	2887-	W 57		25	6702	3		7
	7	3213	5	4014-	W 13		5		9
	9		9	4017	57		5	7118	43
	15		17	4064-	W 15		7	7127	43
	17		17	4085-	B 51		9		45
	27	3236-	B 25		53		9		45
		3240	15	4250	13		15	7130-	W 43
520-	W 13	3245	7		13		17		45
534	7	3449	13	4253	25		17	7142	43
559	5	3454	19	4254	27		21		45
	9		59	4270	27		25	7145-	W 51
	9	3455	13	4455	7		45	7242	43
	11	3456	13		9		57		45
	17	3459	9	4725	15	6703	3	7415	23
	17	3650	3	4730	7		5		25
	31		5		51		5		33
	31	3728	47	5230	25		9	7416	23
	55		49	5745	3		9	7420	13
576	11	3767-	B 5		5		17	7506	25
610	3		9	5746	3		31	7512	13
	5		15		5		31		13
	9		17	5748	13		35	7560	43
2004	25		17	5749	13		43	7590	43
2338	43		45	5927	57		45	7602	57
2500	31		45	5982-	W 47		47	7620-	W 7
	33		47	5998	15		49		43
2551-	W 5		49	6150-	W 23		51	7631-	W 59
	9	3768	51	6192	51		59	7632	25
	9	3783	21		59	6716	43	7644	25
	17		21	6220-	W 27	6926	13	7686	5
	51	3787	31	6228-	W 33		13		9
2556	45		31	6253-	W 31	7015	51		9
	45		43		31	7022	19		17
2560	7		45		33		21		19
2577	31		47	6310-	B 7	7036	15		31
	31		49	6332-	B 57		17		31
	33	3802-	W 47	6333	3		33		43
2583	57		49		27		47		45
2602	57	3854	5		51		49		45
2603	57		9	6334	25		51		47
2605	29		17	6336-	B 7		57		49
2659	9		21	6346	13	7039	5		57
2665	43	3858	19		13		9		59
2685-	W 3	3953-	W 25	6347	13		17	7688	7
	5	3960-	W 15		13		19		47
	7		17	6375-	B 7		21		49
	9	3974-	HW 33		27	7041	3		57
	9	3978	31	6417-	W 13		5	7710-	W 57
	17	3987	3		13		5	7725	13
	17		5	6653	13		9	7727	3
2727	43		9		13		9		5
2745	23		9	6578-	W 57		17		7
	33		17	6681	51		21		9
2774	57		21		53		25		15
2778	25		25	6698	13		29		17
2807	37		29	6701	5		33	7728	15
	39	3991	5		7		43		27
2808	37		5		9		45	7729	7
	39		9		17		45		15
2818	27		17		17		51		17
2821	31		21		25		57	7737-	W 33

NUMERICAL INDEX

Part No.	Page	Part No.	Page	Part No.	Page	Part No.	Page	Part No.	Page
7739	25	9857	41	41528-78	5	42617-78	9		17
7740	27	9859	41		9		17	47743-63	3
7741	13	9866	41		9	42629-78	5		5
	13	9868	41		17		9	47745-72	15
7742	3	10006	5	41531-78	5		17		17
	5		9		9		49	47748-72	15
	43		9		9	42633-78	5	47749-67A	51
	45		17		17		9		53
7744	43		41	41532-78	41		17	47781-78	5
	45		45		45		17		9
	45	11000	7	41534-78	9	42634-78	9		15
7748- W	3	11015	27	41537-78	5	42636-78	9		17
	5	11036	7		9	42639-78	9		17
	5	11085	33		9	42642-78	5	48300-60	11
	9	11105	27		17		9	48315-60	11
	9	11115	7	41538-78	5		9	50210-75	23
	17	11422	25		9		17	50212-77	33
	21		33		9	42643-78	9	50213-78	33
	25	11702	33		17	42644-78	9	50226-75	25
7753	3	11703	33	41542-78	9	42645-78	9		33
	5	12028	11	41565-77	25	43017-66B	11	50227-75	25
	7	12041	51	41621-76	27	43103-72	11		33
	13		53	41781-75	15	43104-72	11	50578-75	25
	27	16280-76	15	41781-77	15	43152-66	11	50700-75	25
	51		17	41782-75	15	43156-63	11	50701-75A	23
7763- W	9	16280-77	15	41783-75	25	43480-75	11	50702-75A	25
7775	5		17	41783-77	25	43733-47	35	50703-75	23
	9	16281-76	15	41810-64A	15	43803-78	5	50972-75	13
	13		17	41811-64A	15		9	52048-75	29
	13	25594-75	7	41834-67	7		17	52048-76	29
	17	26814-67	27		27		21		31
	17	27291-32	27	41841-63	15		25	52056-72A	27
	19	31422-72	23	42269-30	27	43805-78	21	52069-75A	25
	25	31431-75A	33	42330-71	27		21		33
7800- W	43	33256-71	15	42462-75A	7	43808-78	5	52083-72	15
	45	38078-47	15	42464-75A	7		9	52191-75	29
7812- W	25	38712-68	39	42466-75B	7		17	52191-76	29
7825	25	40450-78	5	42467-75	7		21		31
7827- W	25	40451-78	5	42468-75	3		25	52193-75	29
7845	19	40453-78	5		5	43820-75A	19	52193-76	29
	21		5		7	43823-75	19		31
7855- W	43		9	42482-63	7	43930-75	13	52221-76	29
	45		17	42494-63B	7	43933-75	13		31
7867- W	13	40455-78	5	42600-78	5	43935-75A	13	52311-76	27
7874	11	40522-63	3		9		13	52313-76	27
7990	13		5		17	43936-75	13	52315-76	27
7995	13	40537-75	3		17	43936-77	13	52317-76	27
	19	40538-75	3	42602-78	5		13	52319-76	27
	21	40539-75	3		9	47099-77B	25	52320-76	27
7998	43	40543-75	3		9	47192-75	47	52321-76	27
8119- W	35		5		17		49	52322-76	27
8212	23	40546-75	3	42604-78	11	47403-75	25	52323-76	27
8321	23		5	42605-78	17	47437-75	25	52324-76	27
	33	40547-75	3	42606-78	17	47464-76	23	52325-76	27
8480	23		5	42607-78	17	47585-75A	19	52327-76	27
8488- B	23	40940-75	7	42608-78	17		21	52402-78	31
	57	40940-77	7	42609-78	17	47596-75	19		31
8641- B	23	41421-72	15	42610-78	17		21	52403-78	31
	25	41421-77	15	42611-78	17	47598-75	13		31
8685	33	41424-63	15	42612-78	17	47605-75	13	52404-78	31
8687	57	41510-77	7	42613-78	17	47618-77	13		31
8858	15	41513-77	7	42615-78	17	47738-78	5	52405-78	31
	27	41516-77	7	42616-78	17		9		31

NUMERICAL INDEX

Part No.	Page	Part No.	Page	Part No.	Page	Part No.	Page	Part No.	Page
52406-78	31		13	66560-75	35		43	82823-67	55
	31	57199-78	13	66561-75	35		45	82844-63A	55
52407-78	31		13	66564-75	35	71750-75	43	82852-75	25
	31	57210-75	13	69620-75	41		45	82852-77	25
52408-78	25	57215-75	13	69622-75	41	71752-75	43	82948-74	55
	31	57220-75	13	69623-75	41		45	82953-74	55
	31	57225-78	13	69624-75	41	71753-75	43	83032-73	55
	33	57226-75	19	69625-75	41		45	83033-73	55
52451-78	31		21	69626-75	39	71754-77A	47	83034-73	55
52670-75	29	57227-75A	19		41		49	83035-73	55
52670-76	29		21	69627-75	39	71756-75	47	83039-73	55
	31	58106-76	59		41		49	83041-73	55
52672-75	29	58131-66	59	69628-75	41	71757-77	43	83042-73	55
52672-76	29	58310-76	59	70195-69A	41		45	83043-73	55
	31	58311-76	59	70199-63B	41	71758-75	47	83053-63A	55
53240-72	23	58312-76	59	70351-72	41		49	83072-73	55
53470-71	33	58313-76	59	70463-71A	41	71759-75	47	83073-73	55
53498-71	33	58314-76	59	70465-67	41		49	83074-73	55
53500-75	33	58315-76	59	70491-73	53	71761-75	43	83085-73	11
53501-75A	33	58510-76	23	70584-69	41	71762-75	43		55
53574-75	33	58511-76	23	70589-69	41		45	83087-73	55
54585-75	25	58512-76	23	71445-72	43	71763-75	47	83096-63A	55
54586-75	25	58513-76	23	71445-75	45	71765-75	43	83097-63A	55
54587-75	25	60031-61	45	71470-63D	47		45	83098-63A	55
54595-75	25		45		49	71768-78	45	83099-63A	55
54598-75	25	61771-72	23	71476-66A	47		45	83100-73	55
54599-75	25		33	71476-66B	49	71769-78	45	83103-73	55
54640-75	25	66007-63	35	71480-75	47		45	83104-73	55
57053-78	21	66036-72	37	71480-77	47	71770-77	3	83106-63A	55
57066-68	19		39		49		5	83108-74	55
	21	66043-72	37	71506-63	43	71772-77	43	83112-63A	55
57067-68	19		39	71506-77	43		45	83113-73	55
	21	66063-69B	37	71513-66A	3		45	83115-73	55
57070-68	19		39	71700-77	45	71773-77	43	83119-73	55
	21	66070-72	37	71710-78	45	71774-77	41	83125-73	55
57071-68	19		39	71740-75	43	71775-77	41	83126-73	55
	21	66493-67	37		47		45	83131-63	11
57074-68	19		39	71740-77	43	71776-77	41		55
	21	66500-69A	39		47	71795-63A	57	83134-63A	55
57075-69	19	66501-69	37	71740-77A	45	72342-73	53	83140-75	55
	21	66501-76	39		45	72343-73	53	83141-75	55
57076-68	19	66502-69	37		49	72347-73	53	83142-75	11
	21		39	71741-75	43	72352-73	53		55
57077-67	19	66503-69	37	71741-77	43	72379-73	53	83143-75	55
	21	66504-69	37		45	72380-72	53	83163-63A	55
57081-67	19		39		45	72386-73	53	83165-73	55
	21	66505-69	37	71742-75	43	73092-61B	7	83170-75	51
57082-67	19	66505-76	39		45		27	83171-75	51
	21	66506-69	37		45	74601-75	47	83172-75	51
57084-67	19		39	71743-75	43		49	83173-75	51
	21	66507-69	37		45	74602-75	47	83174-75	51
57088-67	19		39	71744-75	43		49	83175-75	51
	21	66508-69	37	71744-77	43	74603-75	47	83176-75	51
57090-67	19	66509-69	37		45		49	83177-75	51
	21	66512-69	37	71746-75	43	74603-77	47	83178-75	51
57098-75	19	66512-76	39	71746-77	43		49	83179-75	51
	21	66513-69	37		45	74893-67	47	83180-75	51
57120-75	13	66513-76	39	71747-75	43		49	83181-75	51
57130-75	13	66514-69	37		45	74894-63A	47	83182-75	51
57135-75A	19	66515-76	39	71748-75	43		49	83183-75	51
	21	66516-76	39	71748-77	43	74895-63	47	83184-75	51
	21	66517-76	39		45		49	83185-75	51
57196-78	13	66518-76	39	71749-75	41	82805-75	55	83186-75	51

NUMERICAL INDEX

Part No.	Page	Part No.	Page	Part No.	Page	Part No.	Page	Part No.	Page
83187-75	51								
83188-75	51								
83189-75	51								
83190-75	5								
	9								
	17								
	51								
	53								
83191-75	51								
83192-75	51								
83193-75	51								
83194-75	51								
83250-75	53								
83252-75	53								
83253-75	53								
83254-75	53								
83255-75	53								
83256-75	53								
83257-75	53								
83259-75	53								
83260-75	53								
83262-75	53								
83263-75	53								
83264-75	53								
83268-75	53								
83961-63A	11								
89465-74	27								
89500-75	57								
89501-75	57								
89503-75	57								
89508-75	57								
89510-75	57								
89511-75	57								
89514-75	57								
89515-75	57								
89516-75	57								
89517-76	57								
89520-77	57								
91015-75	25								
91025-75A	25								
91026-75	25								
91035-78	25								
91102-75	25								
91102-76	25								
91115-75A	25								
91116-75	25								
95671-42	25								

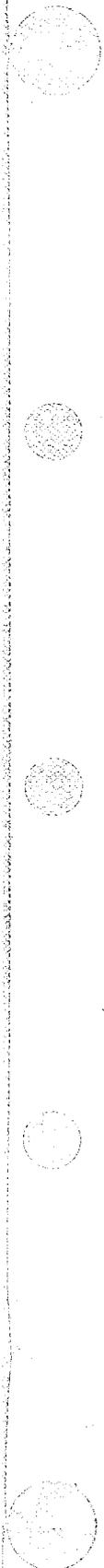



PARTS CATALOG USER'S COMMENT

The Harley-Davidson Technical Publications Department maintains a continuous effort to improve the quality, accuracy and usefulness of its publications. To do this effectively we need user feedback – your critical evaluation of this parts catalog.

Please comment on this catalog's completeness, accuracy, organization, usability and readability.

Did you find errors in this catalog? (please list) _____

How can this catalog be improved? _____

Occupation: _____

Name _____ Dealership _____

Street _____ Department _____

City _____ State _____ Zip _____

99436-78

(Please see other side for cutting, folding and mailing instructions)

Fold Here

PLEASE CUT HERE

Do Not Tear or Staple — Fold Here and Tape Shut



NO POSTAGE
NECESSARY
IF MAILED
IN THE
UNITED STATES

BUSINESS REPLY MAIL

FIRST CLASS PERMIT NO. 1183 MILWAUKEE, WI

POSTAGE WILL BE PAID BY ADDRESSEE



HARLEY-DAVIDSON MOTOR CO., INC.

POST OFFICE BOX 653

MILWAUKEE, WISCONSIN 53201

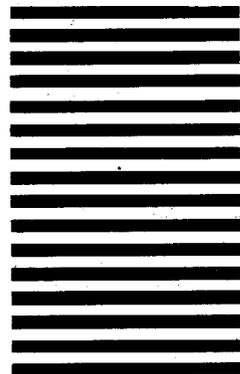





Harley-Davidson

Milwaukee, Wisconsin 53201